

Computational Properties of Argument Systems Satisfying Graph-theoretic Constraints

Paul E. Dunne

Dept. of Computer Science, The University of Liverpool, Liverpool, United Kingdom

Abstract

One difficulty that arises in abstract argument systems is that many natural questions regarding argument acceptability are, in general, computationally intractable having been classified as complete for classes such as NP, co-NP, and Π_2^p . In consequence, a number of researchers have considered methods for specialising the structure of such systems so as to identify classes for which efficient decision processes exist. In this paper the effect of a number of graph-theoretic restrictions is considered: k -partite systems ($k \geq 2$) in which the set of arguments may be partitioned into k sets each of which is conflict-free; systems in which the numbers of attacks originating from and made upon any argument are bounded; planar systems; and, finally, those of k -bounded treewidth. For the class of *bipartite* graphs, it is shown that determining the acceptability status of a *specific* argument can be accomplished in polynomial-time under both credulous and sceptical semantics. In addition we establish the existence of polynomial time methods for systems having bounded treewidth when deciding the following: whether a given (set of) arguments is credulously accepted; if the system has a non-empty preferred extension; has a stable extension; is coherent; has at least one sceptically accepted argument. In contrast to these positive results, however, deciding whether an arbitrary *set* of arguments is “collectively acceptable” remains NP-complete in bipartite systems. Furthermore for both planar and bounded degree systems the principal decision problems are as hard as the unrestricted cases. In deriving these latter results we introduce various concepts of “simulating” a general argument system by a restricted class so allowing any argument system to be translated to one which has both bounded degree and is planar. Finally, for the development of basic argument systems to so-called “value-based frameworks”, we present results indicating that decision problems known to be intractable in their most general form remain so even under quite severe graph-theoretic restrictions. In particular the problem of deciding “subjective acceptability” continues to be NP-complete even when the underlying graph is a binary tree.

Key words: Computational properties of argumentation; argumentation frameworks; computational complexity;

1 Introduction

Since their introduction in the seminal work of Dung [20] abstract argument systems have proven to be a valuable paradigm with which to formalise diverse semantics defining argument “acceptability”. In these a key component is the concept of an “*attack*” relationship wherein the incompatibility of two arguments – p and q , say – may be expressed in terms of one of these “attacking” the other: such relationships may be presented independently of any internal structure of the individual arguments concerned so that the properties of the overall argument system, e.g. which of its arguments may be defended against any attack and which are indefensible, depend solely on the attack relationship rather than properties of individual argument schemata. Among other applications, this abstract view of argumentation has proven to be a powerful and flexible approach to modelling reasoning in a variety of non-classical logics, e.g. [20,12,17].

We present the formal definitions underpinning argument systems in Section 2, including two of the widely-studied admissibility semantics – preferred and stable – introduced in [20]: at this point we simply observe that these describe differing conditions which a maximal set of mutually compatible arguments, S , must satisfy in order to be admissible within some argument system comprising arguments \mathcal{X} with attack relationship $\mathcal{A} \subset \mathcal{X} \times \mathcal{X}$.

Despite the descriptive power offered by abstract argument systems one significant problem is the apparent intractability of many natural questions concerning acceptability under all but the most elementary semantics: such intractability classifications encompassing NP-completeness and co-NP-completeness results of Dimopoulos and Torres [18] and the Π_2^p -completeness classifications presented in Dunne and Bench-Capon [24]. Motivated, at least to some degree, by these negative results a number of researchers have considered mechanisms by which argument systems may be specialised or enriched so that the resulting structures admit efficient decision procedures. Two main strategies are evident: the first, and the principal focus of the present paper, has been to identify purely graph-theoretic conditions leading to tractable methods for those cases within which these are satisfied; the second, which itself may be coupled with graph-theoretic restrictions, is to consider additional structural aspects in developing the basic argument and attack relationship form. Under the first category, [20] already identifies *directed acyclic graphs* (DAGs) as a suitable class, while recent work of Coste-Marquis *et al.* [14] has shown that *symmetric* argument systems – those in which p attacks q if and only if q attacks p – also form a tractable class. Graph-theoretic considerations also feature significantly in work of Baroni *et al.* [3,4].

Probably the two most important exemplars of the second approach are the *Preference based* argumentation frameworks of Amgoud and Cayrol [1] and *Value based* argumentation frameworks introduced by Bench-Capon [7]. While the supporting

motivation for both formalisms is, perhaps, more concerned with providing interpretations and resolution of issues arising from the presence of multiple maximal admissible sets which are mutually inconsistent, both approaches start with an arbitrary argument system, $\langle \mathcal{X}, \mathcal{A} \rangle$, and reduce it to an *acyclic* system, $\langle \mathcal{X}, \mathcal{B} \rangle$ in which $\mathcal{B} \subseteq \mathcal{A}$ this reduction being determined via some additional relationship \mathcal{R} : the main distinction between [1] and [7] being the exact manner in which \mathcal{R} is defined.

In this paper some further classes of graph-theoretic restrictions are considered: *k-partite* directed graphs, *bounded degree* systems, planar argument systems, and those with *k*-bounded treewidth. In the first class, for which the case $k = 2$ is of particular interest, the argument set \mathcal{X} may be partitioned into k pairwise disjoint subsets – $\langle \mathcal{X}_1, \dots, \mathcal{X}_k \rangle$ such that every attack in \mathcal{A} involves arguments belonging to *different* sets in this partition: the special case, $k = 2$, defines the class of *bipartite* directed graphs. The bounded degree class, limits the number of attacks on (the argument’s *in-degree*) and by (its *out-degree*) any $x \in \mathcal{X}$, i.e. $|\{y : \langle y, x \rangle \in \mathcal{A}\}|$ and $|\{y : \langle x, y \rangle \in \mathcal{A}\}|$ are bounded by given values (p, q) , again the special case $p = q = 2$ is of particular interest. The concept of *treewidth*, introduced in work of Robertson and Seymour, e.g. [34], has proven to be a useful aid in developing efficient methods for many computationally hard problems, e.g. via very general approaches such as those of Arnborg *et al.* [2], Courcelle [15,16], even in the case of problems which are not directly graph-theoretic in nature, e.g. Gottlob *et al.* [29].

In the remainder of this paper formal background and definitions are given in Section 2 together with the decision questions considered. Section 3 describes two important systems from [18,24] that feature in a number of subsequent hardness proofs, while Sections 4 and 5 present results concerning, respectively, *k*-partite and bounded degree directed graphs. Planarity is discussed in Section 6 and properties of bounded treewidth systems are given in Section 7. The range of results proved indicate that for many of these restrictions it is possible to obtain efficient decision processes: both credulous and sceptical acceptability of individual arguments may be determined in polynomial time within bipartite systems. In the case of systems with bounded treewidth, similar positive results for a number of properties are derivable using a number of deep results originally obtained in [15,16] and developed in [2]. It turns out, however, that for the development of standard argument systems into value-based frameworks we do not obtain more efficient mechanisms simply by limiting the graph structure: in Section 8 we show that two basic decision problems in this model remain hard even when the underlying graph structure is a binary tree. Conclusions and developments are discussed in Section 9.

2 Finite Argument Systems – Basic Definitions

The following concepts were introduced in Dung [20].

Definition 1 An argument system is a pair $\mathcal{H} = \langle \mathcal{X}, \mathcal{A} \rangle$, in which \mathcal{X} is a finite set of arguments and $\mathcal{A} \subset \mathcal{X} \times \mathcal{X}$ is the attack relationship for \mathcal{H} . A pair $\langle x, y \rangle \in \mathcal{A}$ is referred to as ‘ y is attacked by x ’ or ‘ x attacks y ’. For $S \subseteq \mathcal{X}$, the set of arguments $\mathcal{N}(S)$ is given by

$$\mathcal{N}(S) = \bigcup_{x \in S} \{ y : \langle x, y \rangle \in \mathcal{A} \text{ or } \langle y, x \rangle \in \mathcal{A} \}$$

The convention of excluding “self-attacking” arguments, also observed in [14], is assumed, i.e. for all $x \in \mathcal{X}$, $\langle x, x \rangle \notin \mathcal{A}$. For R, S subsets of arguments in the system $\mathcal{H}(\mathcal{X}, \mathcal{A})$, we say that

- a. $s \in S$ is attacked by R if there is some $r \in R$ such that $\langle r, s \rangle \in \mathcal{A}$.
- b. $x \in \mathcal{X}$ is acceptable with respect to S if for every $y \in \mathcal{X}$ that attacks x there is some $z \in S$ that attacks y .
- c. S is conflict-free if no argument in S is attacked by any other argument in S .
- d. A conflict-free set S is admissible if every $y \in S$ is acceptable w.r.t S .
- e. S is a preferred extension if it is a maximal (with respect to \subseteq) admissible set.
- f. S is a stable extension if S is conflict free and every $y \notin S$ is attacked by S .
- g. \mathcal{H} is coherent if every preferred extension in \mathcal{H} is also a stable extension.

Following the terminology of [14], $\mathcal{H}(\mathcal{X}, \mathcal{A})$ is symmetric if for every pair of arguments x, y in \mathcal{X} it holds that $\langle x, y \rangle \in \mathcal{A}$ if and only if $\langle y, x \rangle \in \mathcal{A}$.

An argument x is credulously accepted if there is some preferred extension containing it; x is sceptically accepted if it is a member of every preferred extension.

Combining the ideas of credulous and sceptical with preferred and stable, provides a number of differing formalisations for the concept of a set of arguments being acceptable: these are sometimes referred to as the credulous preferred/stable semantics and sceptical preferred/stable semantics. Unless we explicitly state otherwise we will usually be considering the preferred variant of these.

We make one further assumption regarding the *graph-theoretic* structure of argument systems: as an *undirected* graph, $\mathcal{H}(\mathcal{X}, \mathcal{A})$ is *connected*. In informal terms, this states that systems do *not* consist of two or more “isolated” graphs.

The concepts of credulous and sceptical acceptance motivate a number of decision problems that have been considered in [18,24].

That problems (a–d) are NP–complete, while (e) is CO-NP–complete follows from results of [18]. Problems (f) and (g) were shown to be Π_2^p –complete in [24].

The questions above are formulated in terms of *single* arguments, it will be useful to consider analogous concepts with respect to *sets*. Thus $\text{CA}_{\{\}} \cup$ denotes the decision problem whose instances are an argument system $\langle \mathcal{X}, \mathcal{A} \rangle$ together with a subset S

Table 1
Decision Problems in Finite Argument Systems

	Problem	Instance	Question
a.	CA	$\mathcal{H}(\mathcal{X}, \mathcal{A}), x \in \mathcal{X}$	Is x credulously accepted?
b.	CA ^S	$\mathcal{H}(\mathcal{X}, \mathcal{A}), x \in \mathcal{X}$	Is x in any <i>stable</i> extension?
c.	PREF-EXT	$\mathcal{H}(\mathcal{X}, \mathcal{A})$	Does \mathcal{H} have a <i>non-empty</i> preferred extension?
d.	STAB-EXT	$\mathcal{H}(\mathcal{X}, \mathcal{A})$	Does \mathcal{H} have any stable extension?
e.	SA ^S	$\mathcal{H}(\mathcal{X}, \mathcal{A}), x \in \mathcal{X}$	Is x in <i>every</i> stable extension?
f.	SA	$\mathcal{H}(\mathcal{X}, \mathcal{A}), x \in \mathcal{X}$	Is x sceptically accepted?
g.	COHERENT	$\mathcal{H}(\mathcal{X}, \mathcal{A})$	Is the system \mathcal{H} coherent?

of \mathcal{X} : the instance being accepted if there is a preferred extension T for which $S \subseteq T$. Similarly, SA_{{}^S} accepts instances for which S is a subset of *every* preferred extension.

In contrast, we have the following more positive results.

Fact 2

- a. *Every argument system \mathcal{H} has at least one preferred extension. (Dung [20])*
- b. *If $\mathcal{H}(\mathcal{X}, \mathcal{A})$ is a DAG then \mathcal{H} has a unique preferred extension. This is also a stable extension and may be found in time linear in $|\mathcal{X}| + |\mathcal{A}|$. ((Dung [20])*
- c. *If $\mathcal{H}(\mathcal{X}, \mathcal{A})$ is symmetric then CA, SA, CA_{{}^S}, and SA_{{}^S} are all polynomial-time decidable. Furthermore \mathcal{H} is coherent. (Coste-Marquis et al. [14]).*
- d. *If $\mathcal{H}(\mathcal{X}, \mathcal{A})$ contains no odd-length simple directed cycles, then \mathcal{H} is coherent. (Dunne and Bench-Capon [24])*
- e. *If $\mathcal{H}(\mathcal{X}, \mathcal{A})$ is coherent then SA(\mathcal{H}, x) can be decided in co-NP.*

Fact 2 (e) is an easy consequence of the sceptical acceptance methods described in work of Vreeswijk and Prakken [36].

While Fact 2 (a) ensures the existence of a preferred extension – a property that is not guaranteed to be the case for stable extensions – it is possible that the *empty set* of arguments (which is always admissible) is the unique such extension. Noting Table 1 (c), whether a given argument system $\mathcal{H}(\mathcal{X}, \mathcal{A})$ has a non-empty preferred extension is unlikely to be efficiently decidable in general.

3 The argument systems \mathcal{H}_Φ and \mathcal{G}_Φ and their properties

A number of our subsequent hardness proofs regarding various graph-theoretic restrictions are obtained by transforming argument systems used in earlier reductions

of [18,24] in classifying the decision problems CA and SA. In order to avoid repetition it will be useful formally to introduce the two systems used in these contexts. Noting that both systems take as their starting point some CNF formula Φ , we denote these subsequently by \mathcal{H}_Φ and \mathcal{G}_Φ .

3.1 The system \mathcal{H}_Φ

The form we describe is virtually identical to that first presented by Dimopoulos and Torres [18, Thm. 5.1, p. 227] where it is used to establish NP-hardness of CA via a reduction from 3-SAT.

Given a CNF formula $\Phi(Z_n) = \bigwedge_{j=1}^m C_j$ with each C_j a disjunction of literals from $\{z_1, \dots, z_n, \neg z_1, \dots, \neg z_n\}$, the argument system, $\mathcal{H}_\Phi(\mathcal{X}, \mathcal{A})$ has

$$\begin{aligned} \mathcal{X} &= \{\Phi, C_1, \dots, C_m\} \cup \{z_i, \neg z_i : 1 \leq i \leq n\} \\ \mathcal{A} &= \{\langle C_j, \Phi \rangle : 1 \leq j \leq m\} \cup \{\langle z_i, \neg z_i \rangle, \langle \neg z_i, z_i \rangle : 1 \leq i \leq n\} \cup \\ &\quad \{\langle z_i, C_j \rangle : z_i \text{ occurs in } C_j\} \cup \{\langle \neg z_i, C_j \rangle : \neg z_i \text{ occurs in } C_j\} \end{aligned}$$

Fig. 1 illustrates \mathcal{H}_Φ for the CNF $\Phi(z_1, z_2, z_3, z_4) = (z_1 \vee z_2 \vee z_3)(\neg z_2 \vee \neg z_3 \vee \neg z_4)(\neg z_1 \vee z_2 \vee z_4)$.

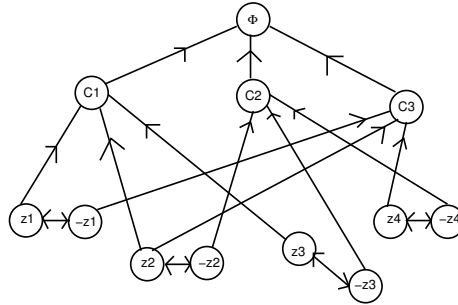

Fig. 1. The Argument System \mathcal{H}_Φ

Fact 3 (Dimopoulos and Torres [18]) Let $\Phi(Z_n)$ be an instance of 3-SAT, i.e. a 3-CNF formula. Then $\Phi(Z_n)$ is satisfiable if and only if $CA(\mathcal{H}_\Phi(\mathcal{X}, \mathcal{A}), \Phi)$.

3.2 The system \mathcal{G}_Φ

The proof that SA is Π_2^p -complete from [24] uses a reduction from QSAT_2^Π instances of which may, without loss of generality, be restricted to 3-CNF formulae,¹ $\Phi(Y_n, Z_n)$, accepted if $\forall \alpha_Y \exists \beta_Z \Phi(\alpha_Y, \beta_Z)$, i.e. for every instantiation of the propositional variables Y_n (α_Y) there is some instantiation of Z_n (β_Z) for which $\langle \alpha_Y, \beta_Z \rangle$ satisfies Φ .

The system $\mathcal{G}_\Phi(\mathcal{W}, \mathcal{B})$ is formed from the system $\mathcal{H}_\Phi(\mathcal{X}, \mathcal{A})$, i.e. $\mathcal{X} \subset \mathcal{W}$ and $\mathcal{A} \subset \mathcal{B}$, so that

$$\begin{aligned} \mathcal{W} &= \{\Phi, C_1, \dots, C_m\} \cup \{y_i, \neg y_i, z_i, \neg z_i : 1 \leq i \leq n\} \cup \{b_1, b_2, b_3\} \\ \mathcal{B} &= \{\langle C_j, \Phi \rangle : 1 \leq j \leq m\} \cup \\ &\quad \{\langle y_i, \neg y_i \rangle, \langle \neg y_i, y_i \rangle, \langle z_i, \neg z_i \rangle, \langle \neg z_i, z_i \rangle : 1 \leq i \leq n\} \cup \\ &\quad \{\langle y_i, C_j \rangle : y_i \text{ occurs in } C_j\} \cup \{\langle \neg y_i, C_j \rangle : \neg y_i \text{ occurs in } C_j\} \cup \\ &\quad \{\langle z_i, C_j \rangle : z_i \text{ occurs in } C_j\} \cup \{\langle \neg z_i, C_j \rangle : \neg z_i \text{ occurs in } C_j\} \cup \\ &\quad \{\langle \Phi, b_1 \rangle, \langle \Phi, b_2 \rangle, \langle \Phi, b_3 \rangle, \langle b_1, b_2 \rangle, \langle b_2, b_3 \rangle, \langle b_3, b_1 \rangle\} \cup \\ &\quad \{\langle b_1, z_i \rangle, \langle b_1, \neg z_i \rangle : 1 \leq i \leq n\} \end{aligned}$$

The resulting system is shown in Fig. 2.

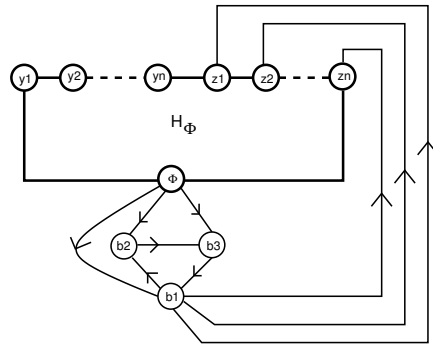

Fig. 2. The Argument System \mathcal{G}_Φ .

Fact 4 (Dunne and Bench-Capon [24])

- a. $\Phi(Y_n, Z_n)$ is accepted as an instance of QSAT_2^Π if and only if $\text{SA}(\mathcal{G}_\Phi, \Phi)$.

¹ The proof in [24], in fact presents a more general translation from arbitrary propositional formulae over the logical basis $\{\wedge, \vee, \neg\}$. Exploiting such translations is a significant motivating device underlying Theorem 12 and, in particular, accounts for the original context of Fig. 8.

b. $\Phi(Y_n, Z_n)$ is accepted as an instance of QSAT_2^{Π} if and only if \mathcal{G}_Φ is coherent.

4 k -partite Argument Systems

In this section² we consider the effect on problem complexity of restricting systems to be k -partite. Our results are summarised in Table 2.

Definition 5 An argument system $\mathcal{H}(\mathcal{X}, \mathcal{A})$ is k -partite if there is a partition of \mathcal{X} into k sets $\langle \mathcal{X}_1, \dots, \mathcal{X}_k \rangle$ such that

$$\forall \langle y, z \rangle \in \mathcal{A} \quad y \in \mathcal{X}_i \Rightarrow z \notin \mathcal{X}_i$$

The term bipartite will be used for the case $k = 2$. It should be noted that, since there is no insistence that each of the partition members be non-empty, any k -partite system is, trivially, also a $(k+t)$ -partite system for every $t \geq 0$. We use the notation $\Gamma^{(k)}$ for the set of all k -partite argument systems.

Table 2
Complexity-theoretic Properties of k -partite Argument Systems

	Decision Problem	Complexity
a.	$\text{CA}^{(2)}$	Polynomial-time
b.	$\text{CA}^{(3)}$	NP-complete
c.	$\text{CA}_{\{\}}^{(2)}$	NP-complete
d.	$\text{SA}^{(2)}$	Polynomial-time
e.	$\text{SA}^{(3)}$	Π_2^p -complete
f.	$\text{SA}_{\{\}}^{(2)}$	Polynomial-time
g.	$\text{SA}_{\{\}}^{(3)}$	Π_2^p -complete
h.	$\text{COHERENT}^{(2)}$	Trivial
i.	$\text{COHERENT}^{(3)}$	Π_2^p -complete

The notations $\text{CA}^{(k)}$, $\text{SA}^{(k)}$, $\text{CA}_{\{\}}^{(k)}$, and $\text{SA}_{\{\}}^{(k)}$ will be used to distinguish the various avatars of the decision problems of interest when instances are required to be k -partite argument systems. Similarly we use $\text{COHERENT}^{(k)}$ to denote the problem of deciding whether a k -partite argument system is coherent. In instances of these problems it is assumed that $\mathcal{H}(\mathcal{X}, \mathcal{A})$ is presented using an appropriate partition of

² The results presented in Theorems 6, 7, and 8 first appeared in a preliminary version of this paper in [23].

\mathcal{X} into k disjoint sets $\langle \mathcal{X}_1, \dots, \mathcal{X}_k \rangle$.³

We first deal with the case of bipartite argument systems ($k = 2$). For other values it is noted that the classifications are largely straightforward consequences of the graph-theoretic constructions described in Section 3.⁴ Notice that it is straightforward to deal with the claim made in Table 2(h): a bipartite argument system cannot have any odd-length cycles, and thus coherence is ensured via Fact 2 (d). In contrast to *undirected* graph structures, the *absence* of odd-length directed cycles, while necessary, is not a *sufficient* condition for an argument system to be bipartite; *symmetric* systems, however, are bipartite systems if and only if the associated undirected graph contains no odd-length cycles.

The main idea underlying Algorithm 1 in proving Theorem 6 is as follows: in a bipartite argument system, $\mathcal{B}(\mathcal{Y}, \mathcal{Z}, \mathcal{A})$ attackers of an argument $y \in \mathcal{Y}$ can only be arguments $z \in \mathcal{Z}$, and defences to such attacks must, themselves, also be arguments in \mathcal{Y} . It follows, therefore, that those arguments of \mathcal{Y} that are attacked by members of \mathcal{Z} upon which no counterattack exists cannot be admissible. Moreover, attacks on \mathcal{Z} furnished by such arguments play no useful function (as counterattacks) and may be eliminated from \mathcal{A} , a process that can lead to further arguments in \mathcal{Z} becoming unattacked. By iterating the process of removing indefensible arguments in \mathcal{Y} and their associated attacks on \mathcal{Z} , this algorithm identifies an admissible subset of \mathcal{Y} .

Theorem 6

- a. $CA^{(2)}$ is polynomial-time decidable.
- b. $SA^{(2)}$ is polynomial-time decidable.

Proof: For (a), given a bipartite argument system, $\mathcal{B}(\mathcal{Y}, \mathcal{Z}, \mathcal{A})$ and $x \in \mathcal{Y} \cup \mathcal{Z}$, without loss of generality assume that $x \in \mathcal{Y}$. Consider the subset, S of \mathcal{Y} that is formed by Algorithm 1.

We claim that $CA^{(2)}(\mathcal{B}, x)$ holds if and only if $x \in S$.

Suppose first that $x \in S \subseteq \mathcal{Y}$. Since $\mathcal{B}(\mathcal{Y}, \mathcal{Z}, \mathcal{A})$ is a bipartite argument system it follows that S is conflict-free. Now consider any argument $z \in \mathcal{Z}$ that attacks S : it must be the case that there is some $y \in S$ that counterattacks z for otherwise at least one argument would have been removed from S at Step 4. In total, S is conflict-free and every argument in S is acceptable with respect to S , i.e. S is an admissible set containing x which is, hence, credulously accepted.

³ Without this, problems arise when checking if an *arbitrary* argument system, \mathcal{H} , is k -partite: for $k \geq 3$ the corresponding decision question is NP-complete.

⁴ It is noted, however, that some extension of the basic construction in Section 3.2 is needed for the results of Table 2(g) and (i).

Algorithm 1. Credulous Acceptance in Bipartite Systems

- 1: $i := 0$; $\mathcal{Y}_0 := \mathcal{Y}$; $\mathcal{A}_0 := \mathcal{A}$
- 2: **repeat**
- 3: $i := i + 1$
- 4: $\mathcal{Y}_i := \mathcal{Y}_{i-1} \setminus \{ y \in \mathcal{Y}_{i-1} : \exists z \in \mathcal{Z} : \langle z, y \rangle \in \mathcal{A}_{i-1} \text{ and } |\{ y \in \mathcal{Y}_{i-1} : \langle y, z \rangle \in \mathcal{A}_{i-1} \}| = 0 \}$
- 5: $\mathcal{A}_i := \mathcal{A}_{i-1} \setminus \{ \langle y, z \rangle : y \notin \mathcal{Y}_i \setminus \mathcal{Y}_{i-1} \}$
- 6: **until** $\mathcal{Y}_i = \mathcal{Y}_{i-1}$
- 7: **return** \mathcal{Y}_i

On the other hand, suppose that x is credulously accepted. Let S be the subset of \mathcal{Y} returned and suppose for the sake of contradiction that $x \notin S$: then there must be some iteration of the algorithm during which $x \in \mathcal{Y}_{i-1}$ but $x \notin \mathcal{Y}_i$. In order for this to occur, we must have a sequence of arguments $\langle z_0, z_1, \dots, z_i \rangle$ in \mathcal{Z} with the property that $|\{ y \in \mathcal{Y}_j : \langle y, z_j \rangle \in \mathcal{A}_j \}| = 0$ with $\langle z_i, x \rangle \in \mathcal{A}_i$. Now any argument y' of \mathcal{Y} attacked by z_0 cannot be credulously accepted since there is no counterattack on z_0 available. It follows that the attacks $\langle y', z \rangle$ provided by such arguments cannot play an effective role in defending another argument and thus can be removed. Continuing in this way, it follows that no argument y'' that is attacked by z_1 is credulously accepted: the only attackers of z_1 are arguments of \mathcal{Y} that are attacked by z_0 and these, we have seen, are indefensible. In total, $x \notin S$ would imply that x is indefensible, a conclusion which contradicts the assumption that x was credulously accepted.

The preceding analysis establishes the algorithm's correctness. The proof of (a) is completed by noting that it runs in polynomial-time: there are at most $|\mathcal{Y}|$ iterations of the main loop each taking only polynomially many (in $|\mathcal{Y} \cup \mathcal{Z}| + |\mathcal{A}|$) steps.

Part (b) follows from (a), Table 2(h) and the observation of [36] that, in coherent systems, an argument is sceptically accepted if and only if none of its attackers are credulously accepted. \square

Examining the structure of Algorithm 1 allows the following characterization of the set of preferred extensions in bipartite systems.

Corollary 1 *Given a bipartite argument system $\mathcal{B}(\mathcal{Y}, \mathcal{Z}, \mathcal{A})$ let $S_{\mathcal{Y}}$ and $S_{\mathcal{Z}}$ be the subsets of \mathcal{Y} and \mathcal{Z} returned by Algorithm 1. Let $T \subseteq \mathcal{Y} \cup \mathcal{Z}$ and for $\mathcal{X} \in \{\mathcal{Y}, \mathcal{Z}\}$, $T_{\mathcal{X}}$ denote $T \cap \mathcal{X}$. Then T is a preferred extension of $\mathcal{B}(\mathcal{Y}, \mathcal{Z}, \mathcal{A})$ if and only if*

$$T = S_{\mathcal{Y}} \setminus \mathcal{N}(T_{\mathcal{Z}}) \cup S_{\mathcal{Z}} \setminus \mathcal{N}(T_{\mathcal{Y}})$$

Turning to the problems $CA_{\{\}}$ and $SA_{\{\}}$, [14] note that in many cases decision problems involving *sets* are “no harder” than the related questions formulated for specific arguments, e.g. for unrestricted argument systems, symmetric argument systems and DAGs, the upper bounds for $CA_{\{\}}$ and $SA_{\{\}}$ are identical to the correspond-

ing upper bounds for CA and SA. In this light, the next result may appear somewhat surprising: although, as has just been shown, $CA_{\{\}}^{(2)}$ is polynomial-time decidable, $CA_{\{\}}^{(2)}$ is likely to be noticeably harder.

Theorem 7

- a. $CA_{\{\}}^{(2)}$ is NP-complete, even for sets containing exactly two arguments.
- b. $SA_{\{\}}^{(2)}$ is polynomial-time decidable.

Proof: For (a), that $CA_{\{\}}^{(2)} \in NP$ is easily demonstrated via the non-deterministic algorithm that guesses a subset T , checks $S \subseteq T$ and that T is admissible.

To show that $CA_{\{\}}^{(2)}$ is NP-hard we use a reduction from the problem *Monotone 3-CNF Satisfiability* (MCS) ([27, p. 259]), instances of which comprise a 3-CNF formula over a set of propositional variables $\{x_1, \dots, x_n\}$,

$$\Phi(x_1, x_2, \dots, x_n) = \bigwedge_{i=1}^m C_i = \bigwedge_{i=1}^m (y_{i,1} \vee y_{i,2} \vee y_{i,3})$$

and each clause, C_i , is defined using exactly three *positive* literals or exactly three *negated* literals, e.g. $(x_1 \vee x_2 \vee x_3) \wedge (\neg x_1 \vee \neg x_2 \vee \neg x_4)$ would define a valid instance of MCS, however $(x_1 \vee \neg x_2 \vee x_3)$ would not. An instance Φ of MCS is accepted if and only if there is an instantiation, $\alpha \in \{\top, \perp\}^n$ under which $\Phi(\alpha) = \top$.

Given $\Phi(x_1, \dots, x_n)$ an instance of MCS let $\{C_1^+, \dots, C_r^+\}$ be the subset of its clauses in which only positive literals occur and $\{D_1^-, \dots, D_s^-\}$ those in which only negated literals are used. Consider the bipartite argument system $\mathcal{B}_{MCS}(\mathcal{Y}, \mathcal{Z}, \mathcal{A})$ in which

$$\begin{aligned} \mathcal{Y} &= \{\Phi^-, C_1^+, \dots, C_r^+, \neg x_1, \dots, \neg x_n\} \\ \mathcal{Z} &= \{\Phi^+, D_1^-, \dots, D_s^-, x_1, \dots, x_n\} \end{aligned}$$

and \mathcal{A} contains

$$\begin{aligned} &\{ \langle x_j, \neg x_j \rangle, \langle \neg x_j, x_j \rangle : 1 \leq j \leq n \} && \cup \\ &\{ \langle C_i^+, \Phi^+ \rangle : 1 \leq i \leq r \} \cup \{ \langle D_i^-, \Phi^- \rangle : 1 \leq i \leq s \} && \cup \\ &\{ \langle \neg x_j, D_i^- \rangle : \neg x_j \text{ occurs in } D_i^- \} && \cup \\ &\{ \langle x_j, C_i^+ \rangle : x_j \text{ occurs in } C_i^+ \} \end{aligned}$$

The instance of $CA_{\{\}}^{(2)}$ is completed by setting $S = \{\Phi^+, \Phi^-\}$.

Suppose that there is some preferred extension, T , of \mathcal{B}_{MCS} for which $\{\Phi^+, \Phi^-\} \subseteq T$, i.e. that $\langle \mathcal{B}_{\text{MCS}}, S \rangle$ defines a positive instance of $\text{CA}_{\{\}}^{(2)}$. Then, for each C_i^+ some argument x_j with $\langle x_j, C_i^+ \rangle \in \mathcal{A}$ must be in T (otherwise the attack $\langle C_i^+, \Phi^+ \rangle$ is undefended); similarly for each D_i^- some argument $\neg x_k$ with $\langle \neg x_k, D_i^- \rangle \in \mathcal{A}$ must be in T . It cannot be the case, however, that *both* x_j and $\neg x_j$ are in T . We can, thus, construct a satisfying instantiation of Φ via $x_j := \top$ if $x_j \in T$, and $x_j := \perp$ if $\neg x_j \in T$.

On the other hand suppose the instance Φ of MCS is satisfiable, using some instantiation α . In this case the set

$$\{\Phi^+, \Phi^-\} \cup \{x_j^+ : x_j = \top \text{ under } \alpha\} \cup \{x_j^- : x_j = \perp \text{ under } \alpha\}$$

is easily seen to be admissible, so that $\langle \mathcal{B}_{\text{MCS}}, \{\Phi^+, \Phi^-\} \rangle$ defines a positive instance of $\text{CA}_{\{\}}^{(2)}$.

Part (b) follows easily from Theorem 6(b) since a set of arguments S is sceptically accepted if and only if each of its constituent members is sceptically accepted. \square

The remaining cases in Table 2 are considered in the following Theorem.

Theorem 8

- a. $\forall k \geq 3$, $\text{CA}^{(k)}$ is NP-complete.
- b. $\forall k \geq 3$, $\text{SA}^{(k)}$ and $\text{COHERENT}^{(k)}$ are Π_2^p -complete.

Proof: The membership proofs are identical to those that hold for the unrestricted versions of each problem. For (a), NP-hardness follows by observing that the argument system \mathcal{H}_Φ given in Section 3.1 is 3-partite: using three colours – $\{R, B, G\}$ say – \mathcal{H}_Φ may be three vertex coloured by assigning R to $\{\Phi, z_1, \dots, z_n\}$; B to $\{\neg z_1, \dots, \neg z_n\}$ and G to $\{C_1, \dots, C_m\}$. The proof of (b) requires techniques introduced in Section 5 applied to the construction \mathcal{G}_Φ of Section 3.2: details are given in Appendix 1. \square

5 Bounded degree systems

In contrast to many of the results of Section 4, the restriction considered in this Section⁵ does not lead to improved algorithmic methods. Our principal interest is in introducing the concept of a given class of argument systems being capable of

⁵ The presentation here is a revised and expanded treatment of ideas originally outlined in [23].

“representing” another class. This is of interest for the following reason. Suppose that Π and Θ are properties of argument systems (where the formal definition of “property” will be clarified subsequently). Furthermore, suppose that any system with property Π can be “represented” (in a sense to be made precise) by another system with property Θ . Assuming such a representation can be constructed efficiently, we would be able to exploit algorithmic methods tailored to systems with property Θ also to operate on systems with property Π : given \mathcal{H} (satisfying Π), form $\mathcal{G}_{\mathcal{H}}$ (with property Θ) and use an algorithm operating on this to decide the question posed of \mathcal{H} . In a more precise sense, we have the formalism presented below.

Definition 9 A property, Π of finite argument systems is a (typically infinite) subset of all possible finite argument systems. We say \mathcal{H} has property Π if $\mathcal{H} \in \Pi$.

The argument system $\mathcal{H}(\mathcal{X}, \mathcal{A})$ is simulated by the argument system $\mathcal{G}(\mathcal{X} \cup \mathcal{Y}, \mathcal{B})$ with respect to credulous admissibility (denoted $\mathcal{G} \sim_{ca} \mathcal{H}$) if

$$\forall S \subseteq \mathcal{X} \quad CA_{\emptyset}(\mathcal{G}(\mathcal{X} \cup \mathcal{Y}, \mathcal{B}), S) \Leftrightarrow CA_{\emptyset}(\mathcal{H}(\mathcal{X}, \mathcal{A}), S)$$

Similarly \mathcal{H} is simulated by \mathcal{G} w.r.t. sceptical admissibility ($\mathcal{G} \sim_{sa} \mathcal{H}$) if

$$\forall S \subseteq \mathcal{X} \quad SA_{\emptyset}(\mathcal{G}(\mathcal{X} \cup \mathcal{Y}, \mathcal{B}), S) \Leftrightarrow SA_{\emptyset}(\mathcal{H}(\mathcal{X}, \mathcal{A}), S)$$

For $\alpha \in \{CA, SA\}$, a property, Π α -represents a property Θ if for every $\mathcal{H}(\mathcal{X}, \mathcal{A}) \in \Pi$ there is some $\mathcal{G}(\mathcal{X} \cup \mathcal{Y}, \mathcal{B}) \in \Theta$ such that $\mathcal{G} \sim_{\alpha} \mathcal{H}$. We say that Π polynomially α -represents Θ if there is some constant k such that, for every $\mathcal{H}(\mathcal{X}, \mathcal{A}) \in \Pi$ there is some $\mathcal{G}(\mathcal{X} \cup \mathcal{Y}, \mathcal{B}) \in \Theta$ such that $|\mathcal{X} \cup \mathcal{Y}| \leq |\mathcal{X}|^k$ and $\mathcal{G} \sim_{\alpha} \mathcal{H}$. Finally we say that a property is (polynomially) α -universal if it (polynomially) α -represents all argument systems.

It will be useful also to view as “polynomially α -universal” those properties that α -represent all but finitely many argument systems.

The class of argument systems considered in this section are those defined by the property, $\Delta^{(p,q)}$ introduced below,

Definition 10 An argument system $\mathcal{H}(\mathcal{X}, \mathcal{A})$ has (p, q) -bounded degree if

$$\forall x \in \mathcal{X} \quad |\{y \in \mathcal{X} : \langle y, x \rangle \in \mathcal{A}\}| \leq p \text{ and } |\{y \in \mathcal{X} : \langle x, y \rangle \in \mathcal{A}\}| \leq q$$

The notation $\Delta^{(p,q)}$ will be used for the set of all (p, q) -bounded degree systems.

Our main result in this section is

Theorem 11

- a. $\Delta^{(2,2)}$ is polynomially CA-universal.
- b. $\Delta^{(2,2)}$ is polynomially SA-universal.

Proof: We prove part (a) only. An identical construction serves for part (b) with the analysis needed for the conditions of simulation w.r.t. sceptical admissibility proceeding in a similar style to the case of credulous admissibility.

Let $\mathcal{H}(\mathcal{X}, \mathcal{A})$ be any finite argument system. Suppose $\mathcal{H} \notin \Delta^{(2,2)}$. Consider any $x \in \mathcal{X}$ for which

$$|\{y : \langle y, x \rangle \in \mathcal{A}\}| = \{y_1, y_2, \dots, y_k\} \text{ and } k \geq 3$$

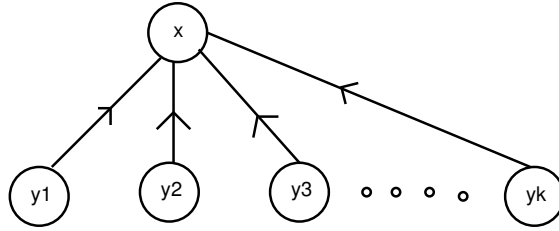

Fig. 3. Argument x attacked by $k \geq 3$ arguments

Consider the system $\mathcal{G}_x^{(k-1)}(\mathcal{X} \cup \{z_1, z_2\}, \mathcal{B})$ formed by introducing new arguments z_1 and z_2 with

$$\mathcal{B} = \mathcal{A} \setminus \{\langle y_i, x \rangle : 2 \leq i \leq k\} \cup \{\langle z_1, x \rangle, \langle z_2, z_1 \rangle\} \cup \{\langle y_i, z_2 \rangle : 1 \leq i \leq k\}$$

i.e. formed by replacing the attacks on x in Fig. 3 with the system in Fig. 4

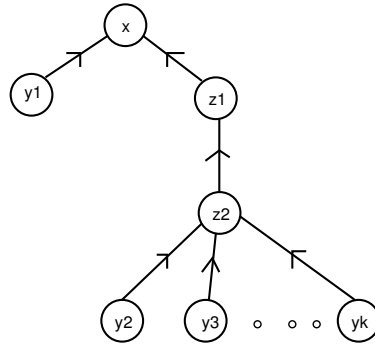

Fig. 4. Reducing k attacks to $k - 1$ attacks

We claim that $\mathcal{G}_x^{(k-1)}(\mathcal{X} \cup \{z_1, z_2\}, \mathcal{B}) \sim_{ca} \mathcal{H}(\mathcal{X}, \mathcal{A})$.

Consider any $T \subseteq \mathcal{X} \cup \{z_1, z_2\}$ defining an admissible set in $\mathcal{G}_x^{(k-1)}$ and let $S = T \setminus \{z_1, z_2\}$. To see that S is conflict-free it suffices to observe that the only way in which T can be conflict-free and S fail to be so is if $\{x, y_i\} \subseteq T$ for some $2 \leq i \leq k$: but in this case, since z_1 attacks x and the only counterattack on z_1 is z_2 , $x \in T$ forces $z_2 \in T$ from which $y_i \notin T$, for every $1 \leq i \leq k$. To see that S also defends itself against any attack if T does so, first suppose that $x \in T$. In this case, not only must some attacker of y_1 be in T (and thus the same attacker is in S) but also since $z_2 \in T$ to defend the attack on x by z_1 , we require that for each attack $\langle y_i, z_2 \rangle$, T must contain some attacker of y_i : again all of these attacks will be members of S . If, on the other hand, $x \notin T$, without loss of generality suppose that $\langle x, p \rangle \in \mathcal{A}$ and that $p \in T$. Then either $y_1 \in T$ (and thus also in S) or $z_1 \in T$. The second of these, however, requires that at least one of $\{y_2, \dots, y_k\}$ is in T to counterattack z_2 . It follows that if $x \notin S$ and attacks $p \in S$ then $\{y_1, \dots, y_k\} \cap S \neq \emptyset$.

In the reverse direction, suppose that $S \subseteq \mathcal{X}$ is admissible in \mathcal{H} . If $x \in S$ then $S \cup \{z_2\}$ is an admissible set of $\mathcal{G}_x^{(k-1)}$. If $x \notin S$ either S is also an admissible set of $\mathcal{G}_x^{(k-1)}$ (if $y_1 \in S$ or x does not attack any argument of S) or $S \cup \{z_1\}$ is such a set (whenever $S \cap \{y_2, \dots, y_k\} \neq \emptyset$). Thus, $\mathcal{G}_x^{(k-1)}(\mathcal{X} \cup \{z_1, z_2\}, \mathcal{B}) \sim_{\text{ca}} \mathcal{H}(\mathcal{X}, \mathcal{A})$.

Noting that the construction does change the number of attacks on arguments other than x , a similar procedure can be applied to any remaining argument attacked by at least three arguments. A near identical construction serves when dealing with those arguments that attack more than two others. \square

Now, recalling that $\Gamma^{(k)}$ is the set of all k -partite argument systems we obtain

Corollary 2 *The property $\Gamma^{(4)} \cap \Delta^{(2,2)}$ is polynomially CA-universal and polynomially SA-universal.*

Proof: Viewed as undirected graphs, via Brooks' Theorem ([9, Thm 6, Ch. 15, p. 337]), with a single exception, every argument system in $\Delta^{(2,2)}$ is 4-colourable. It follows that these are 4-partite. \square

Corollary 3 *Let $\mathcal{Q}^{(2,2)}$ denote either of the decision problems $\{\text{CA}, \text{SA}\}$ restricted to argument systems with the property $\Delta^{(2,2)}$.*

- a. $\text{CA}^{(2,2)}$ is NP-complete.
- b. $\text{SA}^{(2,2)}$ is Π_2^p -complete.

Proof: Apply the construction of Theorem 11 to the systems \mathcal{H}_Φ and \mathcal{G}_Φ presented in Section 3. \square

6 Planar Argument Systems

We recall that a graph $G(V, E)$ is *planar* if it can be drawn (in the plane) in such a way that no two edges of the graph cross each other. Thus, the complete graph on four vertices is planar, e.g. Fig. 5, whilst the complete graph on five vertices is non-planar.

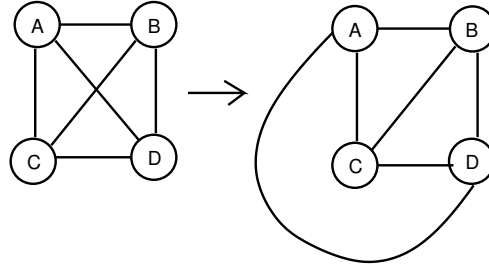

Fig. 5. Planar drawing of K_4 the complete graph on four vertices.

Several graph-theoretic decision problems whose general versions are NP-hard are known to admit polynomial time algorithms when instances must be planar graphs. Examples include not only questions that are immediately resolvable from established properties of planar graphs, e.g. 4 vertex colouring and maximal clique, but also for questions where it is far from obvious that planarity assists in developing efficient algorithms, e.g. the problem of determining whether a graph has a bipartite subgraph containing at least some specified number of edges, [27, GT25, p. 196]. For problems whose complexity status is still open, most notably that of deciding if two given graphs are isomorphic, linear time methods have been found for planar graphs, e.g. [30]. Planarity, however, does not help in the construction of efficient decision procedures for the problems of Table 1. The reductions employed to prove this make use of a device which is of some independent interest: in terms of the formalism introduced in the preceding section this allows us to argue that planarity is a polynomially CA-universal property.

We observe in passing that using the (NP-complete) decision problem PLANAR-3-SAT, whose instances are 3-CNF formulae having planar *clause incidence graphs*,⁶ it is not too difficult to show that $\text{CA}_{\{\}}(\mathcal{H}, S)$ is NP-complete when \mathcal{H} is required to be a planar graph.⁷ We do not consider the proof of this result in any further detail,

⁶ The clause incidence graph of a CNF $\Phi(x_1, \dots, x_n) = \bigwedge_{j=1}^m C_j$, is the bipartite graph with vertex sets $\{x_1, \dots, x_n\}$ and $\{C_1, \dots, C_m\}$ and edges $\{x_i, C_j\}$ for each case when $\neg x_i$ occurs in C_j or x_i occurs in C_j .

⁷ For readers familiar with the relevant graph-theoretic concepts, the instance of $\text{CA}_{\{\}}$ is formed using a planar embedding of the clause incidence graph of Φ – an instance of PLANAR-3-SAT – augmenting it with arguments $\{\phi_1, \phi_2, \dots, \phi_r\}$ one for each *face* of the embedding in which a clause of Φ occurs. These arguments are then attacked by the in-

simply noting that it is subsumed by our proof that $CA(\mathcal{H}, x)$ is NP-complete with \mathcal{H} restricted to planar graphs.

For Q any of the decision problems of Table 1, we let Q^P denote the variant in which the argument system forming part of the instance is planar.

Theorem 12 CA^P is NP-complete.

Proof: It suffices to prove that CA^P is NP-hard, for which purpose we use a reduction from 3-SAT. Given $\Phi(Z_n)$ we first form the system $\mathcal{H}_\Phi(\mathcal{X}, \mathcal{A})$ of Section 3.1 and recall that $\Phi(Z_n)$ is satisfiable if and only if $CA(\mathcal{H}_\Phi, \Phi)$ holds.

The argument system \mathcal{H}_Φ , however, will not in general be planar, e.g. in Fig. 1 there are eleven distinct points where edges cross and thus \mathcal{H}_Φ must be modified to obtain a planar graph, \mathcal{H}_Φ^P , whilst retaining the property that the argument Φ is credulously accepted if and only if $\Phi(Z_n)$ is satisfiable.

The system \mathcal{H}_Φ^P is formed from \mathcal{H}_Φ in two stages. First for each position where two edges⁸ cross, e.g. $\langle p, q \rangle$ and $\langle r, s \rangle$, replace the “crossing point” by an argument which attacks q and s and is attacked by p and r . If the chosen realisation of \mathcal{H}_Φ contains r crossings we denote these new arguments $X_c = \{x_1, x_2, \dots, x_r\}$. We note that $r = O(|\mathcal{A}|^2)$ so the translation is polynomial time computable. Fig. 6 illustrates the outcome of this translation when applied to the argument system of Fig. 1 after replacing the eleven crossings.

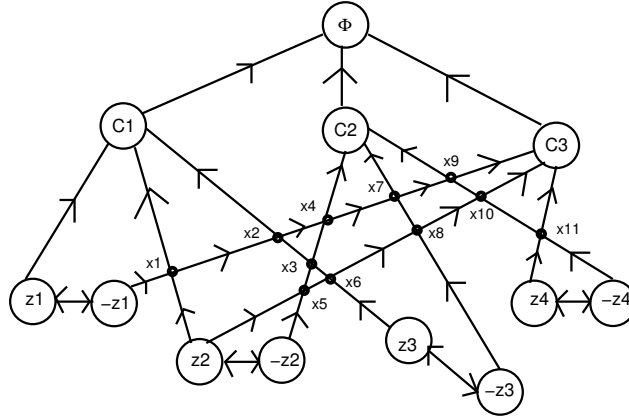

Fig. 6. \mathcal{H}_Φ after crossings replaced by new arguments x_i .

dividual clauses within the relevant face. Following some minor adjustments to represent the presence of *negated* literals in clauses, we can then show that the set $\{\phi_1, \dots, \phi_r\}$ is credulously accepted if and only if Φ is satisfiable.

⁸ It is not necessary to consider the case of three or more edges having a common crossing point: any graph may be drawn in such a way that this case does not arise.

Of course this new system will no longer have the same admissibility properties of the one it replaces: in particular it is not guaranteed to be the case that an admissible set containing Φ can be built if and only if $\Phi(Z_n)$ is satisfiable. For example, for the system shown in Fig. 6, the set $\{\Phi, z_1, z_2, z_3, z_4, x_3, x_8, x_9\}$ is admissible, however, the corresponding instantiation of $\langle z_1, z_2, z_3, z_4 \rangle$ by $z_i := \top$ gives $\Phi(\top, \top, \top, \top) \equiv \perp$. In order to restore the desired behaviour we systematically replace each new argument introduced with a planar argument system.

The typical environment in this case is shown in Fig. 7(a). We have arguments (z and y) that (in \mathcal{H}_Φ) attacked arguments q and p : the attacks $\langle z, q \rangle$ and $\langle y, p \rangle$ crossing in the drawing of \mathcal{H}_Φ and the crossing point replaced by an argument (x) so that the attacks present are now $\langle z, x \rangle$, $\langle y, x \rangle$, $\langle x, p \rangle$, and $\langle x, q \rangle$. In Fig. 7(b), x in turn is replaced by a *planar system* linking arguments z and y with new arguments y_b and z_d with y_b attacking p and z_d attacking q . In order to ensure this replacing system operates correctly it must have the property that in any preferred extension, S , of the resulting system it holds: $z \in S$ if and only if $z_d \in S$ and $y \in S$ if and only if $y_b \in S$.

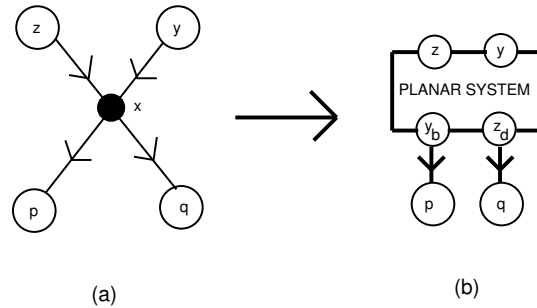

Fig. 7. Crossing edges in \mathcal{H}_Φ and their replacement

Before describing the exact design of the replacing system, however, we specify the order in which the X_c are replaced. We say that the argument y of \mathcal{H}_Φ is a *literal* if $y \in \{z_i, \neg z_i \mid 1 \leq i \leq n\}$ and now observe that the set of arguments, X_c may be ordered using the labelling approach presented in Algorithm 2 to assign a unique number $\lambda(x)$ to each $x \in X_c$ with $1 \leq \lambda(x) \leq r$. For the example of Fig. 6 an ordering produced by this algorithm is $\langle x_1, x_5, x_{11}, x_6, x_8, x_3, x_2, x_4, x_7, x_{10}, x_9 \rangle$.

The construction of the planar system \mathcal{H}_Φ^P is completed by replacing the arguments $x \in X_c$ in order of increasing value of their label $\lambda(x)$ with a copy of the planar crossover gadget given in Fig. 8.⁹ We denote by \mathcal{W} the arguments of \mathcal{H}_Φ^P (noting that $\mathcal{X} \subseteq \mathcal{W}$ and $X_c \cap \mathcal{W} = \emptyset$); and its attacks by \mathcal{B} (observing that each of the attacks $\langle C_j, \Phi \rangle \in \mathcal{A}$ is also in \mathcal{B}).

⁹ Readers familiar with research literature on planar realisations of Boolean networks may recognise that the structure of Fig. 8 derives from that of the planar crossover formed from twelve binary $\neg\wedge$ -elements, cf. [32] and [22, Ch. 6, pp. 404-5].

Algorithm 2. Ordering of Arguments in X_c

$\lambda(x) := 0 \forall x \in X_c$

$T := X_c; k := 1$

while $k \leq r$ **do**

if $\exists x \in T$: x is attacked by two literals **then**

$\lambda(x) := k; T := T \setminus \{x\}$

else if $\exists x \in T$: x is attacked by a literal and $x' \in X_c \setminus T$ **then**

$\lambda(x) := k; T := T \setminus \{x\}$

else

 Choose any $x \in T$ with both attackers of x in $X_c \setminus T$

$\lambda(x) := k; T := T \setminus \{x\}$

end if

$k := k + 1$

end while

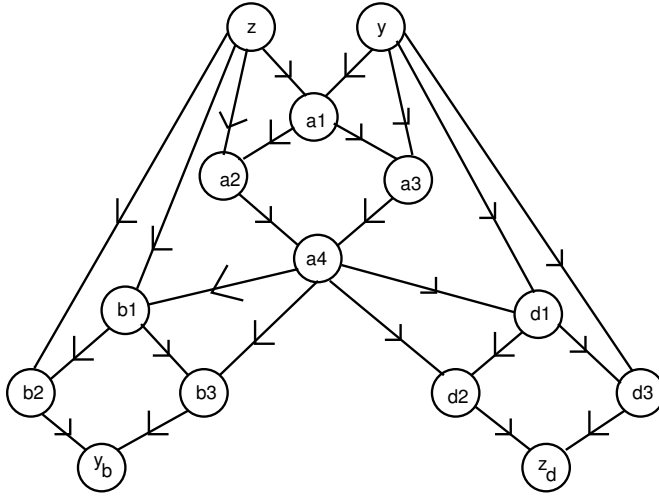

Fig. 8. Planar crossover gadget

The resulting system, \mathcal{H}_Φ^P , is planar: it remains to show that Φ is credulously accepted in \mathcal{H}_Φ^P if and only if $\Phi(Z_n)$ is satisfiable. In \mathcal{H}_Φ , S is a preferred extension containing Φ if and only if $S = \{\Phi, y_1, y_2, \dots, y_n\}$ with $y_i \in \{z_i, \neg z_i\}$ defining an instantiation satisfying $\Phi(Z_n)$, i.e. $z_i = \top$ if $y_i = z_i$ and $z_i = \perp$ if $y_i = \neg z_i$, it therefore is sufficient to prove for the crossover gadget of Fig. 8 that whenever S is a preferred extension of \mathcal{H}_Φ^P , $z \in S \Leftrightarrow z_d \in S$ and $y \in S \Leftrightarrow y_b \in S$. We need only consider the first of these as an identical proof covers the second. To simplify the analysis, it is useful to note that \mathcal{H}_Φ and \mathcal{H}_Φ^P are both *coherent*: the only cycles are those of length two formed by the n pairs $\{z_i, \neg z_i\}$, i.e. \mathcal{H}_Φ and \mathcal{H}_Φ^P contain no odd length cycles and coherence follows from Fact 2(d). Given this, every preferred extension, S , of \mathcal{H}_Φ^P is also a *stable* extension so that any $q \notin S$ must be attacked by some $p \in S$.

Consider any preferred extension $S \subseteq \mathcal{W}$ of \mathcal{H}_Φ^P and an occurrence of the crossover gadget which, without loss of generality, we take as labelled in Fig. 8. Suppose $z \in S$ and consider the two possibilities $y \in S$ and $y \notin S$. The first of these, gives $a_4 \in S$: each of $\{a_1, a_2, a_3\}$ is attacked by $\{y, z\}$, however a_4 is only attacked by $\{a_2, a_3\}$ and so (from stability) must be in S . From $\{y, z, a_4\} \subseteq S$ it follows that $\{b_1, b_2, b_3, d_1, d_2, d_3\} \cap S = \emptyset$ and thence, again via stability, $\{y, z, a_4\} \subseteq S$ since no attackers of these can belong to S . For the second possibility, $y \notin S$, some attacker of y (y' say) must belong to S and we deduce that $\{z, y', a_3\} \subseteq S$ and $a_4 \notin S$. In this case, however, it must hold that $d_1 \in S$ (this is only attacked by a_4 and y) and thence $z_d \in S$ (since neither of its attackers - d_2 and d_3 can belong to S). In summary if $z \in S$ then $z_d \in S$ regardless of the status of y .

On the other hand suppose that $z \notin S$ so that some attacker of z , z' is in S . Again we have the two possibilities $y \in S$ and $y \notin S$. In the former case, $\{z', y, a_2\} \subseteq S$ and $\{a_4, d_1, d_3\} \cap S = \emptyset$. From this we must have $d_2 \in S$ (since its only attackers are d_1 and a_4) from which it follows that $z_d \notin S$ as required. Finally in the second case with $y \notin S$, some attacker y' of y is in S . From $\{y, z\} \cap S = \emptyset$ we deduce that $\{y', z', a_1, a_4\} \subseteq S$ (y and z are the only attackers of a_1), and thence $\{d_1, d_2\} \cap S = \emptyset$. In this case, however, it must hold that $d_3 \in S$ as its only attackers are y and d_1 : in consequence $z_d \notin S$ as required. In total we have that $z \notin S$ implies $z_d \notin S$, completing the proof that the crossover gadget has the desired behaviour.

It is now easy to see that Φ is credulously accepted in the planar system \mathcal{H}_Φ^P if and only if $\Phi(Z_n)$ is satisfiable. If $\{y_1, \dots, y_n\}$ is a set of literals defining a satisfying instantiation of $\Phi(Z_n)$ then each clause C_j must contain a literal from this set. Choosing the argument z_i in \mathcal{W} if $y_i = z_i$ and the argument $\neg z_i$ otherwise, we can build an admissible subset S of \mathcal{W} which attacks each argument C_j (either the literal itself or that propagated via the crossover gadget that replaced $\langle x, C_j \rangle$), so that Φ can be added to S in forming a preferred extension. On the other hand if Φ is credulously accepted then from a preferred extension containing Φ and the attacks on each C_j in S we identify a set of literals that will satisfy $\Phi(Z_n)$.

We deduce that CA^P is NP-complete as claimed. \square

In the analysis demonstrating that the crossover gadget of Fig. 8 operated correctly, we relied on the fact that the system in which it was used was coherent and that thus for any given preferred extension, S , arguments $q \notin S$ could be assumed to be attacked by some argument $p \in S$. We cannot, however, rely on this assumption in attempting to translate arbitrary non-planar argument systems to planar schemes, and thus it is unclear whether directly replacing crossing points using the crossover gadget would produce a system with similar admissibility properties. It turns out, however, that it is possible to transform *any* argument system, \mathcal{H} , into a planar system, \mathcal{H}^P in such a way that questions regarding credulous admissibility of arguments in \mathcal{H} may be posed of corresponding arguments in \mathcal{H}^P . In order to do this a rather more indirect construction is needed.

Theorem 13 *Planarity is polynomially CA-universal.*

Proof: Let $\mathcal{H}(\mathcal{X}, \mathcal{A})$ be any finite argument system with $\mathcal{X} = \{x_1, x_2, \dots, x_n\}$. Consider the propositional formula $\Psi^{\mathcal{H}}(X_n)$ defined from $\mathcal{H}(\mathcal{X}, \mathcal{A})$ as

$$\Psi^{\mathcal{H}}(X_n) = \bigwedge_{\langle x_i, x_j \rangle \in \mathcal{A}} (\neg x_i \vee \neg x_j) \wedge (\neg x_j \vee \bigvee_{x_k : \langle x_k, x_i \rangle \in \mathcal{A}} x_k)$$

If $\alpha = \langle a_1, \dots, a_n \rangle$ is any satisfying instantiation of $\Psi^{\mathcal{H}}$ then the subset $S(\alpha)$ of \mathcal{X} chosen via $x_i \in S \Leftrightarrow a_i = \top$ is an admissible set in \mathcal{H} .

The formula $\Psi^{\mathcal{H}}$ is in CNF and so we can define another argument system – $\mathcal{F}_{\Psi}^{\mathcal{H}}$ simply by using the construction of Section 3.1. Furthermore we can now apply the planarization method of Theorem 12 ($\mathcal{F}_{\Psi}^{\mathcal{H}}$ is coherent irrespective of whether \mathcal{H} is so). Let $\mathcal{F}_{\Psi}^{\mathcal{H}, P}$ be the resulting planar argument system. Now although it is not the case that $\mathcal{F}_{\Psi}^{\mathcal{H}, P} \sim_{\text{ca}} \mathcal{H}$ – every subset of $\{x_1, x_2, \dots, x_n\}$ describes an admissible set in $\mathcal{F}_{\Psi}^{\mathcal{H}, P}$ – it is easily modified to a system $\mathcal{H}_{\Psi}^{\mathcal{H}, P}$ which is planar and satisfies $\mathcal{H}_{\Psi}^{\mathcal{H}, P} \sim_{\text{ca}} \mathcal{H}$. To achieve this, we add a new argument, u , to the set of arguments forming $\mathcal{F}_{\Psi}^{\mathcal{H}, P}$ together with attacks $\{\langle \Psi, u \rangle\} \cup \{\langle u, x_i \rangle, \langle u, \neg x_i \rangle : 1 \leq i \leq n\}$.

Notice that a planar realisation of $\mathcal{H}_{\Psi}^{\mathcal{H}, P}$ is straightforward to construct from the planar realisation of $\mathcal{F}_{\Psi}^{\mathcal{H}, P}$. Now let \mathcal{Y} consist of the arguments $\{\neg x_i : 1 \leq i \leq n\}$ together with $\{u, \Psi\}$, the arguments representing clauses of $\Psi^{\mathcal{H}}$ and those introduced during the transformation of $\mathcal{F}_{\Psi}^{\mathcal{H}}$ to the planar system $\mathcal{F}_{\Psi}^{\mathcal{H}, P}$, i.e. arising by replacing crossing points with copies of the schema in Fig. 8.

We claim that $\mathcal{H}_{\Psi}^{\mathcal{H}, P} \sim_{\text{ca}} \mathcal{H}$. Consider any admissible subset T of $\mathcal{X} \cup \mathcal{Y}$, the arguments of $\mathcal{H}_{\Psi}^{\mathcal{H}, P}$. To see that $S = T \setminus \mathcal{Y}$ is an admissible set in \mathcal{H} , notice that

$$(\Psi \notin T) \text{ and } (T \text{ is admissible}) \Leftrightarrow (T = \emptyset)$$

since the argument u attacks each y in $\{x_i, \neg x_i : 1 \leq i \leq n\}$ and is only attacked by Ψ , so it is no longer the case that every non-empty subset of $\{x_1, x_2, \dots, x_n\}$ describes an admissible set in $\mathcal{H}_{\Psi}^{\mathcal{H}, P}$ (as happened with $\mathcal{F}_{\Psi}^{\mathcal{H}, P}$). So without loss of generality we may assume $\Psi \in T$. Now the definition of $\Psi^{\mathcal{H}}(X_n)$ and the properties of $\mathcal{F}_{\Psi}^{\mathcal{H}}$ ensure that since the instantiation $x_i = \top$ if $x_i \in T$, $x_i = \perp$ if $x_i \notin T$ satisfies $\Psi^{\mathcal{H}}$ the set $\{x_i : x_i \in T\}$ is an admissible subset in \mathcal{H} : this, set however, is exactly the set of arguments in $S = T \setminus \mathcal{Y}$.

Similarly, if $S \subseteq \mathcal{X}$ is admissible in \mathcal{H} , it may be extended to an admissible set in $\mathcal{H}_{\Psi}^{\mathcal{H}, P}$ by adding the arguments $\{\Psi\}$, $\{\neg x_i : x_i \notin S\}$ and those from the crossover elements whose inclusion is forced by the subset of $\{x_i, \neg x_i : 1 \leq i \leq n\}$ corresponding to the satisfying instantiation of $\Psi^{\mathcal{H}}(X_n)$. \square

Corollary 4 $\text{PREF-EXT}^{\text{P}}$ is NP-complete.

Proof: Immediate by noting that $\mathcal{H}_{\Phi}^{\text{P}}$ modified by the addition of the argument u as described in the proof of Theorem 13, has a non-empty preferred extension if and only if $\text{CA}(H_{\Phi}^{\text{P}}, \Phi)$. \square

Corollary 5 Let $\mathcal{P}^{(p,q),k}$ be the class of planar argument systems in the set $\Delta^{(p,q)} \cap \Gamma^{(k)}$. The property $\mathcal{P}^{(2,2),4}$ is polynomially CA-universal.

Proof: From Theorem 13 planarity is polynomially CA-universal. The transformation described in Theorem 11 preserves planarity, thus the result follows by combining Theorem 13, Theorem 11 and Corollary 3. \square

In fact, analysing the structure of $\mathcal{H}_{\Psi}^{\mathcal{H},\text{P}}$ from the proof of Theorem 13 we obtain a stronger result,

Corollary 6 The property $\mathcal{P}^{(3)}$ satisfied by 3-partite planar argument systems is polynomially CA-universal.

Proof: Given $\mathcal{H}(\mathcal{X}, \mathcal{A})$ form the planar system $\mathcal{H}_{\Psi}^{\mathcal{H},\text{P}}$ of Theorem 13. It is straightforward to show that this system is 3 vertex colourable and hence 3-partite. \square

Finally, paralleling the result of Theorem 12 we have,

Theorem 14

- a. SA^{P} is Π_2^{P} -complete.
- b. $\text{COHERENT}^{\text{P}}$ is Π_2^{P} -complete.

Proof: Exactly as the reduction from QSAT_2^{Π} outlined in Section 3.2, however, with the CNF instance $\Phi(Y_n, Z_n)$ implemented as the argument system $\mathcal{H}_{\Phi}^{\text{P}}$ instead of \mathcal{H}_{Φ} . \square

7 Bounded Treewidth

Treewidth, which may be informally understood as a measure of the extent to which a graph differs from a tree, is known to provide a significant aid in developing efficient algorithmic approaches, particularly in the case of graphs whose treewidth may be bounded by a constant value k . A useful survey of results concerning graphs with bounded treewidth is presented in [11]. With some minor differences, we follow the treatment given in Arnborg *et al.* [2] for the definition of treewidth in Defn. 15 and for the description of the language of monadic second order logic.

The second of these admits the use of powerful general tools for synthesising efficient decision algorithms for an extensive range of NP-hard graph problems when the graphs in question have bounded treewidth.

Definition 15 A tree decomposition of a directed graph $H(X, A)$ is a pair $\langle T, S \rangle$, where $T(V, F)$ is a tree and $S = \{S_1, S_2, \dots, S_r\}$ is a family of subsets of X with $r = |V|$ for which

- a. $\bigcup_{i=1}^r S_i = X$.
- b. For all $\langle x, y \rangle \in A$ there is at least one¹⁰ $S_i \in S$ for which $\{x, y\} \subseteq S_i$.
- c. For each $x \in X$, the subgraph of $T(V, F)$ induced by the set $V_x = \{V_i : x \in S_i\}$ is connected, i.e. a subtree of $T(V, F)$.

The width of a tree decomposition $\langle T, S \rangle$ of $H(X, A)$ is $\max_{S_i \in S} |S_i| - 1$; the treewidth of $H(X, A)$ – denote $tw(H)$ – is the minimum width over all tree decompositions of H .

We denote by $W^{(k)}$ the class of all argument systems $\mathcal{H}(\mathcal{X}, \mathcal{A})$ whose treewidth is at most k .

Consider structures of the form $\langle \mathcal{X}, \mathcal{A} \rangle$ where $\mathcal{X} = \{x_1, \dots, x_n\}$ is a finite set of arguments and $\mathcal{A} \subset \mathcal{X} \times \mathcal{X}$ an attack relation. The language, L , of *monadic second-order logic (MSOL)* for this class of structures contains the standard propositional connectives $\neg, \wedge, \vee, \rightarrow, \leftrightarrow, \neg$ – individual variable symbols x, y, z etc. –, predicates, and quantifiers (\exists, \forall) . In addition, and distinguishing it from first-order logic, L contains *set* variable symbols, U, V, W , etc., the set membership symbol (\in) and allows quantification over set variables.

We note that the scheme presented in [2] is rather more elaborated. The corresponding structure would be $\langle D, \mathcal{X}, \mathcal{A}, \mathbf{hd}, \mathbf{tl} \rangle$ where \mathcal{X} and \mathcal{A} are unary predicates on elements of the set D , i.e. $\mathcal{X}(d)$ holds if and only if d is an argument; $\mathcal{A}(d)$ if and only if d is an attack. To relate attacks to their constituent arguments, \mathbf{hd} and \mathbf{tl} are binary predicates defined so that $\mathbf{hd}(b, c)$ if b is an attack whose source is the argument c ; similarly $\mathbf{tl}(b, c)$ holds whenever b is an attack directed at the argument c : thus $\langle x, y \rangle \in \mathcal{A}$ would be realised as $\mathcal{X}(x) \wedge \mathcal{X}(y) \wedge \exists d \mathcal{A}(d) \wedge \mathbf{hd}(d, x) \wedge \mathbf{tl}(d, y)$. For reasons of clarity we eschew this level of precision. We note that, where we write, e.g. $\exists U \subseteq \mathcal{X} P(U)$ (for some predicate P), within the formal style of [2], this could be expressed by $\exists U (\forall u u \in U \rightarrow \mathcal{X}(u)) \wedge P(U)$; similarly $\forall U \subseteq \mathcal{X} P(U)$ is equivalent to $\forall U (\forall u u \in U \rightarrow \mathcal{X}(u)) \rightarrow P(U)$.

Now given a well-formed MSOL sentence $\Phi(\mathcal{X}, \mathcal{A})$ typically some argument systems, \mathcal{H} , will satisfy¹¹ Φ and others fail to do so, i.e. such sentences provide

¹⁰ [2, Defn. 3.1, p. 314] requires *exactly* one, however, the distinction is not significant.

¹¹ The satisfaction relation $\Phi \models \mathcal{H}$ is defined in the usual inductive style via the structure of the MSOL sentence Φ .

a mechanism for specifying *properties* of finite argument systems. Formally we say an argument system property, Π , is *MSOL-definable* if there is a well-formed MSOL sentence, $\Phi(\mathcal{X}, \mathcal{A})$ such that

$$\forall \mathcal{H}(\mathcal{X}, \mathcal{A}) \quad \mathcal{H} \in \Pi \quad \Leftrightarrow \quad \Phi \models \mathcal{H}$$

For example, the property of an argument system being bipartite, $\mathcal{H}(\mathcal{X}, \mathcal{A}) \in \Gamma^{(2)}$, is MSOL-definable as shown by the sentence,

$$BI(\mathcal{X}, \mathcal{A}) = \exists U \exists V \forall x (x \in U \vee x \in V) \wedge (\neg(x \in U) \vee \neg(x \in V)) \wedge (\forall y (\langle x, y \rangle \in \mathcal{A}) \rightarrow (x \in U \leftrightarrow y \in V))$$

That is the system $\langle \mathcal{X}, \mathcal{A} \rangle$ is bipartite whenever there are two sets (U and V) such that: every x belongs to at least one of these ($x \in U$ or $x \in V$); no x belongs to both; and should $\langle x, y \rangle$ be an attack in \mathcal{A} , exactly one of x and y is in U . Thus, the system with $\mathcal{X} = \{x_1, x_2, x_3\}$ and $\mathcal{A} = \{\langle x_1, x_2 \rangle, \langle x_2, x_3 \rangle, \langle x_3, x_1 \rangle\}$ fails to satisfy $BI(\mathcal{X}, \mathcal{A})$ whereas with $\mathcal{A}' = \{\langle x_1, x_2 \rangle, \langle x_2, x_3 \rangle, \langle x_2, x_1 \rangle\}$ $BI(\mathcal{X}, \mathcal{A}')$ is satisfied (choose $U = \{x_1, x_3\}$ and $V = \{x_2\}$).

Although not all graph-theoretic properties are MSOL-definable, for those which are – irrespective of the computational complexity for instances in general – the following result of Courcelle [15,16] is of significance respecting decision methods for MSOL-definable properties restricted to graphs with treewidth k .

Fact 16 (*Courcelle’s Theorem, [15,16] also [2]*) *Let \mathcal{K} be a class of graphs for which $\forall G \in \mathcal{K} \text{ tw}(G) \leq k$ for some constant $k \in \mathbb{N}$ and Π be any MSOL-definable property. Given $G \in \mathcal{K}$ and a width k tree decomposition of G , $G \in \Pi$ is decidable in linear time.*

Recall that $W^{(k)}$ is the class of finite argument systems $\mathcal{H}(\mathcal{X}, \mathcal{A})$ for which a tree decomposition of width k exists.

Theorem 17 *For all constant $k \in \mathbb{N}$, given $\mathcal{H}(\mathcal{X}, \mathcal{A}) \in W^{(k)}$ together with a width k tree decomposition of $\mathcal{H}(\mathcal{X}, \mathcal{A})$ each of the following decision problems are decidable in linear time.*

- a. PREF-EXT(\mathcal{H}).
- b. STAB-EXT(\mathcal{H})
- c. COHERENT(\mathcal{H}).
- d. *There is at least one sceptically accepted argument in \mathcal{H} .*

Proof: Given Fact 16 it suffices to give MSOL sentences expressing each of these properties.

a. $PREF-EXT(\mathcal{X}, \mathcal{A})$

$$\exists U \subseteq \mathcal{X} (U \neq \emptyset) \wedge ADM(\mathcal{X}, \mathcal{A}, U)$$

where $ADM(\mathcal{X}, \mathcal{A}, U)$ is the predicate

$$\begin{aligned} \forall x \in \mathcal{X} \forall y \in \mathcal{X} \langle x, y \rangle \in \mathcal{A} \rightarrow & (\neg(x \in U) \vee \neg(y \in U)) \wedge \\ & (y \in U \rightarrow (\exists z(z \in U) \wedge \langle z, x \rangle \in \mathcal{A})) \end{aligned}$$

Note that we use the abbreviated form $U \neq \emptyset$ rather than the more involved $\exists u \in \mathcal{X} (u \in U)$. Thus, the given expression represents the property of $\langle \mathcal{X}, \mathcal{A} \rangle$ having a non-empty preferred extension via the conditions that there is some non-empty subset (U) of \mathcal{X} which is admissible, i.e. U is conflict-free and for any argument $x \notin U$ attacking an argument $y \in U$, there is some $z \in U$ that counterattacks x .

b. $STAB-EXT(\mathcal{X}, \mathcal{A})$

$$\exists U \subseteq \mathcal{X} ADM(\mathcal{X}, \mathcal{A}, U) \wedge \forall x \in \mathcal{X} \neg(x \in U) \rightarrow (\exists z \in U \langle z, x \rangle \in \mathcal{A})$$

That is, $\langle \mathcal{X}, \mathcal{A} \rangle$ has a stable extension if there is a subset U of \mathcal{X} which is admissible and attacks any argument not contained in it.

c. $COHERENT(\mathcal{X}, \mathcal{A})$

$$\forall U \subseteq \mathcal{X} PREF(\mathcal{X}, \mathcal{A}, U) \rightarrow STABLE(\mathcal{X}, \mathcal{A}, U)$$

where $STABLE(\mathcal{X}, \mathcal{A}, U)$ is the predicate,

$$ADM(\mathcal{X}, \mathcal{A}, U) \wedge \forall x \in \mathcal{X} \neg(x \in U) \rightarrow (\exists z \in U \langle z, x \rangle \in \mathcal{A})$$

and $PREF(\mathcal{X}, \mathcal{A}, U)$ the predicate

$$ADM(\mathcal{X}, \mathcal{A}, U) \wedge MAXIMAL(\mathcal{X}, \mathcal{A}, U)$$

with $MAXIMAL(\mathcal{X}, \mathcal{A}, U)$ defined as,

$$\forall W \subseteq \mathcal{X} \forall Z \subseteq \mathcal{X} ((Z = U \cup W) \wedge ADM(\mathcal{X}, \mathcal{A}, Z)) \rightarrow (W \subseteq U)$$

Again we use abbreviated forms $Z = U \cup W$ and $W \subseteq U$ noting,

$$Z = U \cup W \equiv \forall x \in \mathcal{X} (x \in Z) \leftrightarrow (x \in U \vee x \in W)$$

$$W \subseteq U \equiv \forall x \in \mathcal{X} (x \in W) \rightarrow (x \in U)$$

In total this expression captures the concept of coherence via: any subset of \mathcal{X} which is a preferred extension is also stable. A subset, U , being a preferred extension if it is both admissible and maximal, i.e. for every W for which $U \cup W$ is admissible it holds that W is a subset of U .

d. There is at least one sceptically accepted argument in $\mathcal{H}(\mathcal{X}, \mathcal{A})$.

$$\exists x \in \mathcal{X} \forall U \subseteq \mathcal{X} \text{ PREF}(\mathcal{X}, \mathcal{A}, U) \rightarrow (x \in U)$$

□

Although Theorem 17 establishes the existence of efficient algorithms for decision problems whose complexities in general are NP and Π_2^p -complete, it does not aid with problems concerning the properties of specific arguments within a given system, e.g. $\text{CA}(\mathcal{H}, x)$. Suppose, however, we define $D(\mathcal{H})$ as

$$\max_{x \in \mathcal{X}} |\{ y : \langle y, x \rangle \in \mathcal{A} \text{ or } \langle x, y \rangle \in \mathcal{A} \}|$$

then we can obtain algorithms whose run-time is $O(f(q)n^c)$ for $\text{CA}_{\{\}}(\mathcal{H}, S)$: here f is some fixed function $f : \mathbf{N} \rightarrow \mathbf{N}$, $n = |\mathcal{X}|$, c is a constant (independent of \mathcal{H}) and q is the parameter $\text{tw}(\mathcal{H}) \times D(\mathcal{H})$, that is, in terms of the framework of *fixed-parameter complexity* pioneered by Downey and Fellows [19], $\text{CA}_{\{\}}(\mathcal{H}, S)$ is fixed-parameter tractable (FPT) with respect to the parameter q .

In order to prove this we exploit results from Gottlob *et al.* [29] in which a parameter with respect to which CNF-SAT is FPT was presented.

Definition 18 Let $\Phi(Z_n)$ be a CNF formula with clause set $\{C_1, C_2, \dots, C_m\}$. The primal graph of Φ , denoted $\text{P}_{\Phi}(Z_n, E)$, is the (undirected) graph with vertices labelled by the propositional variables defining Φ , and whose edge set, E , is,

$$\{ \{z_i, z_j\} : z_i \text{ and } z_j \text{ occur as variables in some clause } C \text{ of } \Phi. \}$$

Fact 19 (Gottlob *et al.* [29]) CNF-SAT is FPT w.r.t. the parameter $\text{tw}(\text{P}_{\Phi})$.

Theorem 20 $\text{CA}_{\{\}}$ is FPT w.r.t. the parameter $\text{tw}(\mathcal{H}) \times D(\mathcal{H})$.

Proof: Let $\mathcal{H}(\mathcal{X}, \mathcal{A})$ have $\text{tw}(\mathcal{H}) = r$ and consider the CNF formula, $\Psi^{\mathcal{H}}(X_n)$, as defined in the proof of Theorem 13, i.e.

$$\Psi^{\mathcal{H}}(X_n) = \bigwedge_{\langle x_i, x_j \rangle \in \mathcal{A}} (\neg x_i \vee \neg x_j) \wedge (\neg x_j \vee \bigvee_{x_k : \langle x_k, x_i \rangle \in \mathcal{A}} x_k)$$

Notice that $\text{P}_{\Psi}^{\mathcal{H}}(X_n, E)$ contains the undirected form of $\mathcal{H}(\mathcal{X}, \mathcal{A})$ as a subgraph by virtue of the clause set $\bigwedge_{\langle x_i, x_j \rangle \in \mathcal{A}} (\neg x_i \vee \neg x_j)$. The additional edges of $\text{P}_{\Psi}^{\mathcal{H}}$ are

those arising from the clauses $(\neg x_j \vee \bigvee_{x_k : \langle x_k, x_i \rangle \in \mathcal{A}} x_k)$. The edges, $E_{\langle x_i, x_j \rangle}$ in E contributed by this clause associated with the attack $\langle x_i, x_j \rangle$ being

$$E_{\langle x_i, x_j \rangle} = \{ \{x_j, x_k\} : \langle x_i, x_j \rangle \in \mathcal{A} \text{ and } \langle x_k, x_i \rangle \in \mathcal{A} \} \cup \{ \{x_k, x_l\} : \langle x_k, x_i \rangle \in \mathcal{A} \text{ and } \langle x_l, x_i \rangle \in \mathcal{A} \}$$

For each $x_i \in \mathcal{X}$ define the set of edges X_i by

$$X_i = \{ \{y_j, z_k\} : \langle y_j, x_i \rangle \in \mathcal{A} \text{ and } \langle x_i, z_k \rangle \in \mathcal{A} \} \cup \{ \{y_j, y_k\} : \langle y_j, x_i \rangle \in \mathcal{A} \text{ and } \langle y_k, x_i \rangle \in \mathcal{A} \} \cup \{ \{z_j, z_k\} : \langle x_i, z_j \rangle \in \mathcal{A} \text{ and } \langle x_i, z_k \rangle \in \mathcal{A} \}$$

Then if $H(X, A)$ is the undirected form of $\mathcal{H}(\mathcal{X}, \mathcal{A})$ then not only is $H(X, A)$ a subgraph of $P_{\Psi}^{\mathcal{H}}(X_n, E)$, but $P_{\Psi}^{\mathcal{H}}(X_n, E)$ is in turn a subgraph of H^{aug} where H^{aug} has vertex set X_n and edge set

$$F^{\text{aug}} = A \cup \bigcup_{x_i \in X} X_i$$

From these it observations it follows that $tw(H) \leq tw(P_{\Psi}^{\mathcal{H}}) \leq tw(H^{\text{aug}})$ and thus bounding the width of a tree-decomposition of H^{aug} gives an upper bound on the treewidth of the primal graph $P_{\Psi}^{\mathcal{H}}(X_n, E)$ of $\Psi^{\mathcal{H}}(X_n)$.

Let $\langle T, S \rangle$ be a width r tree decomposition of $\mathcal{H}(\mathcal{X}, \mathcal{A})$, with $S = \{S_1, S_2, \dots, S_m\}$, $S_i \subseteq \mathcal{X}$ and $T(V, F)$ the tree structure linking the family of sets indexed by $V = \{V_1, \dots, V_m\}$. Form the family of sets $Y = \{Y_1, Y_2, \dots, Y_m\}$ via

$$Y_i = S_i \cup \bigcup_{x_i \in \mathcal{X}} \{y, z : \langle y, x \rangle \in \mathcal{A} \text{ or } \langle x, z \rangle \in \mathcal{A}\}$$

With this, $\langle T, Y \rangle$ is a tree decomposition of $H^{\text{aug}}(X, F^{\text{aug}})$. Furthermore, its width is at most $(D(H)+1)(tw(H)+1)-1$: each S_i contains at most $tw(H)+1$ members, each of which can contribute at most $D(H)$ new elements to S_i in addition to those already present. It follows that

$$\begin{aligned} tw(P_{\Psi}^{\mathcal{H}}) &\leq tw(H) + D(H)(tw(H) + 1) \\ &= (D(H) + 1)(tw(H) + 1) - 1 \end{aligned}$$

Thus, given an instance $\langle \mathcal{H}, S \rangle$ of CA_{\exists} and a width r tree decomposition of \mathcal{H} , we may now apply the methods described in [29] to test satisfiability of the CNF

formula

$$\Phi(X_n) = \left(\bigwedge_{x \in S} x \right) \wedge \Psi^{\mathcal{H}}(X_n)$$

via a tree decomposition of P_{Φ} having width at most $(D(H) + 1)(r + 1) - 1$. \square

8 Value-based Argument Frameworks

To conclude we consider the effect that restricting the underlying graph structure has with respect to value-based argument systems. We recall the following definitions from Bench-Capon [7].

Definition 21 A value-based argumentation framework (VAF), is defined by a triple $\langle \mathcal{H}(\mathcal{X}, \mathcal{A}), \mathcal{V}, \eta \rangle$, where $\mathcal{H}(\mathcal{X}, \mathcal{A})$ is an argument system, $\mathcal{V} = \{v_1, v_2, \dots, v_k\}$ a set of k values, and $\eta : \mathcal{X} \rightarrow \mathcal{V}$ a mapping that associates a value $\eta(x) \in \mathcal{V}$ with each argument $x \in \mathcal{X}$.

An audience for a VAF $\langle \mathcal{X}, \mathcal{A}, \mathcal{V}, \eta \rangle$, is a binary relation $\mathcal{R} \subset \mathcal{V} \times \mathcal{V}$ whose (ir-reflexive) transitive closure, \mathcal{R}^* , is asymmetric, i.e. at most one of $\langle v, v' \rangle, \langle v', v \rangle$ are members of \mathcal{R}^* for any distinct $v, v' \in \mathcal{V}$. We say that v_i is preferred to v_j in the audience \mathcal{R} , denoted $v_i \succ_{\mathcal{R}} v_j$, if $\langle v_i, v_j \rangle \in \mathcal{R}^*$. We say that α is a specific audience if α yields a total ordering of \mathcal{V} .

Using VAFs, ideas analogous to those introduced in Defn. 1 by relativising the concept of “attack” using that of *successful* attack with respect to an audience. Thus,

Definition 22 Let $\langle \mathcal{X}, \mathcal{A}, \mathcal{V}, \eta \rangle$ be a VAF and \mathcal{R} an audience. For arguments x, y in \mathcal{X} , x is a successful attack on y (or x defeats y) with respect to the audience \mathcal{R} if: $\langle x, y \rangle \in \mathcal{A}$ and it is not the case that $\eta(y) \succ_{\mathcal{R}} \eta(x)$.

Replacing “attack” by “successful attack w.r.t. the audience \mathcal{R} ”, in Defn. 1 (b)–(f) yields definitions of “conflict-free”, “admissible set” etc. relating to value-based systems, e.g. S is conflict-free w.r.t. to the audience \mathcal{R} if for each x, y in S it is not the case that x successfully attacks y w.r.t. \mathcal{R} . It may be noted that a conflict-free set in this sense is not necessarily a conflict-free set in the sense of Defn. 1 (c): for x and y in S we may have $\langle x, y \rangle \in \mathcal{A}$, provided that $\eta(y) \succ_{\mathcal{R}} \eta(x)$, i.e. the value promoted by y is preferred to that promoted by x for the audience \mathcal{R} .

Bench-Capon [7] proves that every specific audience, α , induces a unique preferred extension within its underlying VAF: we use $P(\langle \mathcal{X}, \mathcal{A}, \mathcal{V}, \eta \rangle, \alpha)$ to denote this extension. Analogous to the concepts of credulous and sceptical acceptance, in VAFs the ideas of *subjective* and *objective* acceptance arise,

Table 3

Decision Problems in Value-based Argument Frameworks

Problem	Instance	Question
Subjective Acceptance (SBA)	$\langle \mathcal{X}, \mathcal{A}, \mathcal{V}, \eta \rangle; x \in \mathcal{X}$	$\exists \alpha : x \in P(\langle \mathcal{X}, \mathcal{A}, \mathcal{V}, \eta \rangle, \alpha)$?
Objective Acceptance (OBA)	$\langle \mathcal{X}, \mathcal{A}, \mathcal{V}, \eta \rangle; x \in \mathcal{X}$	$\forall \alpha : x \in P(\langle \mathcal{X}, \mathcal{A}, \mathcal{V}, \eta \rangle, \alpha)$?

Regarding these questions, [26,8] show the former to be NP–complete and the latter co-NP–complete. Our main result in this section is that, unlike the case of standard argument systems, even within very limited graph classes, both of these problems remain computationally hard.¹² Formally we have,

Theorem 23 *Let $SBA^{(T)}$ and $OBA^{(T)}$ be the decision problems of Table 3 with instances restricted to those for which the graph-structure $\langle \mathcal{X}, \mathcal{A} \rangle$ is a tree.*

- a. $SBA^{(T)}$ is NP–complete.
- b. $OBA^{(T)}$ is co-NP–complete.

Proof: Membership in NP (for $SBA^{(T)}$) and co-NP (for $OBA^{(T)}$) follows from membership in these classes for the general versions.

For part (a), to show that $SBA^{(T)}$ is NP–hard we use a reduction from 3-SAT. It will be convenient (although is not essential to the proof) to restrict instances, $\Phi(Z_n) = \bigwedge_{j=1}^m C_j$, to those in which no variable z of Z_n occurs in *more than* 3 clauses¹³. Notice that given this restriction, without loss of generality, we may assume that for each variable z the literal $\neg z$ occurs in exactly one clause of Φ ; the literal z in at most two (and at least one) clause of Φ .

For each variable z_i of Φ let the values $f(i)$, $s(i)$, and $n(i)$ be

$$\begin{aligned} f(i) &= \min\{j : z_i \text{ occurs in } C_j\} \\ s(i) &= \max\{j : z_i \text{ occurs in } C_j\} \\ n(i) &= j : \neg z_i \text{ occurs in } C_j \end{aligned}$$

Should z_i occur exactly once in positive form then $f(i) = s(i)$.

We can now construct the instance $(\langle T_\Phi(\mathcal{X}, \mathcal{A}), \mathcal{V}_\Phi, \eta \rangle, x)$ of $SBA^{(T)}$.

¹² Theorem 23 subsumes the result presented in [23, Thm. 4, p. 93] where it was proven that $SBA^{(2)}$ is NP–complete, i.e. when the underlying system is bipartite.

¹³ see, e.g. [33, Propn. 9.3] for one proof that this variant of 3-SAT remains NP–hard.

Its argument set \mathcal{X} comprises (at most) $6n + m + 1$ arguments,

$$\begin{aligned} \mathcal{X} = & \{\Phi, C_1, C_2, \dots, C_m\} \cup \{z_i^1, z_i^2, z_i^3 : 1 \leq i \leq n\} \\ & \cup \{\neg z_i^1, \neg z_i^2, \neg z_i^3 : 1 \leq i \leq n\} \end{aligned}$$

(If z_i occurs exactly once in positive form then neither z_i^2 nor $\neg z_i^2$ occur in \mathcal{X} .)

The set of attacks, \mathcal{A} , is formed by

$$\begin{aligned} \mathcal{A} = & \{ \langle C_j, \Phi \rangle : 1 \leq j \leq m \} \cup \\ & \{ \langle \neg z_i^1, z_i^1 \rangle, \langle \neg z_i^2, z_i^2 \rangle : 1 \leq i \leq n \} \cup \\ & \{ \langle z_i^3, \neg z_i^3 \rangle : 1 \leq i \leq n \} \cup \\ & \{ \langle z_i^1, C_{f(i)} \rangle, \langle z_i^2, C_{s(i)} \rangle : 1 \leq i \leq n \} \cup \\ & \{ \langle \neg z_i^3, C_{n(i)} \rangle : 1 \leq i \leq n \} \end{aligned}$$

The value set, \mathcal{V}_Φ of the instance contains $2n + 1$ members,

$$\mathcal{V}_\Phi = \{c\} \cup \{pos_i, neg_i : 1 \leq i \leq n\}$$

Finally the mapping, η from \mathcal{X} to \mathcal{V}_Φ is defined via

$$\eta(x) = \begin{cases} c & \text{if } x \in \{\Phi, C_1, \dots, C_m\} \\ pos_i & \text{if } x \in \{z_i^1, z_i^2, z_i^3\} \\ neg_i & \text{if } x \in \{\neg z_i^1, \neg z_i^2, \neg z_i^3\} \end{cases}$$

The construction for the CNF formula $\Phi(z_1, z_2, z_3, z_4)$ defined by

$$(z_1 \vee z_2 \vee z_3)(\neg z_2 \vee \neg z_3 \vee \neg z_4)(\neg z_1 \vee z_2 \vee z_4)$$

is illustrated in Fig. 9.

It is easy to see that $T_\Phi(\mathcal{X}, \mathcal{A})$ is a tree. To complete the instance of $\text{SBA}^{(T)}$ we set the argument x to be Φ . We now claim that $(\langle T_\Phi(\mathcal{X}, \mathcal{A}), \mathcal{V}_\Phi, \eta \rangle, \Phi)$ is accepted as an instance of $\text{SBA}^{(T)}$ if and only if $\Phi(Z_n)$ is satisfiable.

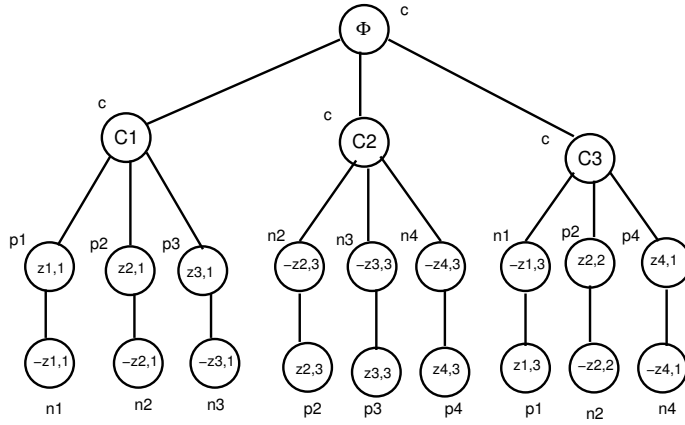

Fig. 9. T_Φ for $\Phi = (z_1 \vee z_2 \vee z_3)(\neg z_2 \vee \neg z_3 \vee \neg z_4)(\neg z_1 \vee z_2 \vee z_4)$

Suppose that $\Phi(Z_n)$ is satisfied by some instantiation $\underline{a} = \langle a_1, a_2, \dots, a_n \rangle$ of Z_n . Consider any specific audience α for which

$$\begin{aligned}
pos_i \succ_\alpha neg_i & \text{ if } a_i = \top \\
neg_i \succ_\alpha pos_i & \text{ if } a_i = \perp \\
pos_i \succ_\alpha c & \quad \forall 1 \leq i \leq n \\
neg_i \succ_\alpha c & \quad \forall 1 \leq i \leq n
\end{aligned}$$

Consider the subset $S(\underline{a})$ of \mathcal{X} chosen as

$$\{\Phi\} \cup \{z_i^1, z_i^2 : a_i = \top\} \cup \{\neg z_i^3 : a_i = \perp\}$$

We claim that $S(\underline{a})$ is admissible with respect to the audience α . The only attacks on Φ are from the arguments C_j , however, since \underline{a} satisfies Φ , each clause has at least one true literal with this instantiation: thus C_j is successfully attacked by one of $\{z_i^1, z_i^2\}$ whenever $a_i = \top$ and $j \in \{f(i), s(i)\}$; similarly C_j is successfully attacked by $\neg z_i^3$ whenever $a_i = \perp$ and $j = n(i)$. Furthermore the attacks on $\{z_i^1, z_i^2 : a_i = \top\}$ by $\{\neg z_i^1, \neg z_i^2\}$ are not successful on account of the value ordering $pos_i \succ_\alpha neg_i$. In the same way, the attack on $\neg z_i^3$ by z_i^3 fails whenever $a_i = \perp$ since $neg_i \succ_\alpha pos_i$. We deduce that $S(\underline{a})$ is admissible and thus Φ subjectively accepted if $\Phi(Z_n)$ is satisfiable.

On the other hand suppose Φ is subjectively accepted and let α be a specific audience with $S \subseteq \mathcal{X}$ an admissible set w.r.t. α that contains Φ . Noting that $\eta(\Phi) = \eta(C_j) = c$ for each C_j it follows that $S \cap \{C_1, \dots, C_m\} = \emptyset$ and, thus, each C_j must be successfully attacked by some y_i w.r.t. α , with the (unique) attack on this y_i , i.e. $\neg z_i^k$ if $y_i = z_i^k$, z_i^3 if $y_i = \neg z_i^3$ failing to succeed. Now let $\{y_1, y_2, \dots, y_m\}$ be the set of arguments for which y_j successfully attacks C_j w.r.t. α and construct

the (partial) instantiation $\langle a_1, \dots, a_n \rangle$ of Z_n with

$$\begin{aligned} a_i &= \top \text{ if } \{z_i^1, z_i^2\} \cap \{y_1, \dots, y_m\} \neq \emptyset \\ a_i &= \perp \text{ if } \neg z_i^3 \in \{y_1, \dots, y_m\} \end{aligned}$$

It now suffices to observe that this instantiation is well-defined. If both $\neg z_i^3$ and z_i^k occur in $\{y_1, \dots, y_m\}$, from the fact that α is a specific audience either $pos_i \succ_\alpha neg_i$ or $neg_i \succ_\alpha pos_i$: in the former case, $\neg z_i^3$ is successfully attacked by z_i^3 (and, hence, could not belong to S); in the latter z_i^k is successfully attacked by $\neg z_i^k$ and, again could not belong to S . We deduce that the partial instantiation $\langle a_1, \dots, a_n \rangle$ is well-defined and satisfies $\Phi(Z_n)$.

In total, Φ is subjectively accepted in the system $\langle T_\Phi(\mathcal{X}, \mathcal{A}), \mathcal{V}_\Phi, \eta \rangle$ if and only if $\Phi(Z_n)$ is satisfiable.

Part (b) uses a similar reduction from UNSAT restricted to 3-CNF instances of the same form as part (a). Given $\langle T_\Phi(\mathcal{X}, \mathcal{A}), \mathcal{V}_\Phi, \eta \rangle$ as described earlier the instance of $OBA^{(T)}$ is formed by adding one additional argument, Φ' , to \mathcal{X} whose sole attacker is the argument Φ and with $\eta(\Phi') = c$. In this construction Φ' is acceptable w.r.t. to every specific audience if and only if Φ is *not* subjectively acceptable. Using an identical argument to (a), the latter holds if and only if $\Phi(Z_n)$ is unsatisfiable. \square

Corollary 7 $SBA^{(T)}$ is NP-complete and $OBA^{(T)}$ is co-NP-complete even if instances are restricted to binary trees.

Proof: Apply the translation of Theorem 11 to the trees constructed in the proof of Theorem 23, assigning the value c to each new argument introduced. This translation and value allocation affects neither the subjective acceptability of Φ nor the objective acceptability of Φ' . With the exception of the root (i.e. the arguments Φ and Φ' respectively), each argument in the trees so formed attacks exactly one other argument. Similarly, with the exception of the leaf arguments which have no attackers and Φ' (which has exactly one attacker), each argument is attacked by exactly two others. \square

One feature of the reduction in Theorem 23 (as, indeed, of the reduction for general VAFs given in [26,8]) is that the number of *values* ($2n+1$) is of the same order as the number of *arguments* in the system: in the reduction $4n+m+1 \leq |\mathcal{X}| \leq 6n+m+1$, however, given the restrictions on Φ it is easily seen that $2n/3 \leq m \leq n$ and hence, $|\mathcal{V}| = \Theta(|\mathcal{X}|)$. Our final result indicates that even insisting that $|\mathcal{V}| = o(|\mathcal{X}|)$ does not lead to tractable cases.

Theorem 24 Let $SBA^{(T,\epsilon)}$ be the decision problem $SBA^{(T)}$ in which instances are restricted to those in which $|\mathcal{V}| \leq |\mathcal{X}|^\epsilon$. $\forall \epsilon > 0$ $SBA^{(T,\epsilon)}$ is NP-complete.

Proof: Let $(\langle T_\Phi(\mathcal{X}, \mathcal{A}), \mathcal{V}_\Phi, \eta \rangle, \Phi)$ be the instance of $\text{OBA}^{(T)}$ constructed in the proof of Theorem 23 (b). Given $\epsilon > 0$, choose $K_\epsilon \in \mathbf{N}$ as $K_\epsilon = \lceil \epsilon^{-1} \rceil$. An instance of $\text{SBA}^{(T, \epsilon)}$ is formed by taking $r = |\mathcal{X}|^{K_\epsilon - 1}$ copies of $T_\Phi - \{T_1, T_2, \dots, T_r\}$. Letting ϕ_i denote the argument forming the root of T_i , the instance is completed by adding one further argument, $\Phi^{(\epsilon)}$ with $\eta(\Phi^{(\epsilon)}) = c$ and attacks $\langle \phi_i, \Phi^{(\epsilon)} \rangle$ for each $1 \leq i \leq r$. Recalling that ϕ_i is objectively accepted if and only if Φ is unsatisfiable it is easily seen that $\Phi^{(\epsilon)}$ is subjectively accepted if and only if Φ is satisfiable. The number of values in the constructed instance is $|\mathcal{V}_\Phi| = O(|\mathcal{X}|)$, however, the number of arguments is $|\mathcal{X}|^{K_\epsilon}$ and this is now a valid instance of $\text{SBA}^{(T, \epsilon)}$. \square

9 Conclusions and Development

In this paper we have considered how the complexity of a number of important decision questions in both standard and value-based argument systems is affected under various graph-theoretic restrictions: the system being k -partite; each argument being attacked by and attacking some maximum number of arguments; planar systems; and systems with bounded treewidth.

Overall the picture apparent regarding the efficacy of graph-theoretic restrictions in admitting efficient algorithmic methods is somewhat mixed. For quite general classes – planar and bounded degree systems – the complexity of decision questions remains unchanged from that of the unrestricted case. In contrast, for more limited classes, to the known examples of DAGs and symmetric frameworks can now be added bipartite systems and those with k -bounded treewidth. The nature of what characterises “efficient restrictions” from those which offer no gains may seem rather arbitrary, e.g. bipartite systems are tractable however 3-partite systems are not. A partial explanation of such phenomena is offered by our notions of “polynomial universality”. Thus, although, for example, planarity is not a property of every finite argument system, by virtue of Theorem 13 there is no loss of generality (with respect to credulous acceptance issues) in assuming planarity since any system is transformable to a related planar system. Notwithstanding the fact that such translations, in general, do not simplify decision processes, there are potential applications exploiting polynomially universal properties in representing argument systems. For example, consider multiagent environments dedicated to maintaining information about admissible and preferred sets within a dynamically evolving system, knowledge concerning which is distributed over distinct agents. In earlier work, Baroni *et al.* [4] have shown the graph-theoretic concept of *strongly connected component* (SCC) decompositions provides a useful mechanism with which to approach this environment. One can envisage complementing such techniques by exploiting 4-partiteness and/or planarity as universal properties: the former sug-

gests a natural partition of arguments over four agents with the set maintained by each being conflict-free and questions about a specific argument, p say, requiring local resolution via the (at most two) agents allocated its attackers; similar methods, using properties of planar graphs, e.g. the separator results of Lipton and Tarjan [31], may also offer useful mechanisms. Such treatments are the subject of current work.

We conclude by raising a select number of interesting open issues.

9.1 Open problems within k -partite systems

- B1. What is the complexity of $CA_{\{\}}^{(2),P}$, i.e. when instances are planar bipartite graphs *and* the set of arguments in the instance is constant size, e.g. as in the proof that $CA_{\{\}}^{(2)}$ is NP-complete given in Theorem 7(a)? The crossover gadget of Fig. 8 is not bipartite and thus cannot be used to replace crossing points in the reduction from MCS. We note that $CA_{\{\}}^{(2),P}$ can be shown NP-complete via an involved reduction from PLANAR-3-SAT. One drawback to this reduction, however, is that the number of arguments in the instance set may be $O(m)$ where m is the number of clauses in the planar CNF formula Φ .
- B2. Corollary 1 characterises the set of preferred extensions within a given bipartite argument system. Can this characterisation be developed to construct efficient methods for *counting* or *enumerating* these? Here, given that there may be exponentially many distinct preferred extensions, the term “efficient enumeration procedure” is in the sense of Goldberg [28].

9.2 Open problems with bounded treewidth systems

Potentially the most interesting suite of issues arises from the results on bounded treewidth decision problems given in Theorems 17 and 20. Although following the algorithm synthesis template of, for example [2], produces a linear time algorithm via some MSOL sentence and width k tree decomposition, such algorithms are likely to be rather opaque with the linear time method concealing large constant factors that increase rapidly with the treewidth bound.¹⁴ Given such eventualities it is tempting to view the algorithms guaranteed by Courcelle’s Theorem as “proof of

¹⁴ While the comparison is rather unfair the relationship between the property captured by a complex MSOL expression and the width k algorithm synthesised is analogous to that of a high-level programming language description and the binary machine code resulting from its compilation. In addition, we recall that (relative to the full formal description of [2]) the sentences given in the proof of Theorem 17 require further development in order to eliminate constructs such as $U \neq \emptyset$, $V \subseteq W$, etc. prior to applying the algorithm construction process.

concept”, i.e. that efficient algorithms exist in principle, rather than as viable solutions in themselves. This interpretation then raises the question of forming practical algorithmic methods. Thus suppose one limits attention to systems of treewidth 2 or 3, relying on the nature of argument systems as might arise in real settings to be of this form. Rather than synthesising methods indirectly via Courcelle’s Theorem, one could attempt to develop practical *direct* methods. There are several promising indications that this is a realistic objective: the precise characterisation of those graphs having treewidth 2, e.g. [11, Thm. 42, p. 22]; and the dynamic programming templates discussed in [10].

Two similar issues arise with respect to the methods discussed for determining credulous acceptability in Theorem 20. Firstly, although arguably of a less extreme nature, the algorithm for deciding $CA(\mathcal{H}, x)$ in the case $tw(\mathcal{H}) = r$ and $D(\mathcal{H}) = d$ is rather indirect involving, as it does, a translation into CNF.¹⁵ Thus there is, again, the issue of finding direct algorithmic solutions, i.e not via CNF-SAT formulations, for systems with small treewidth, e.g. $tw(\mathcal{H}) \leq 3$. Even without such methods, however, the nature of our translation raises one immediate issue: the dependency on $D(\mathcal{H})$ in bounding the treewidth of the primal graph of $\Psi_{\mathcal{H}}$. Our upper estimate of $(D(\mathcal{H}) + 1)(tw(\mathcal{H}) + 1) - 1$ is extremely conservative and a careful analysis of the primal graph relative to the structure of \mathcal{H} itself might well improve it. Of perhaps greater interest, however, is the relationship between $tw(\mathcal{H})$ and $tw(\mathcal{G})$ with $\mathcal{G} \in \Delta^{(2,2)}$ the system resulting from Theorem 11(a) for which $\mathcal{G} \sim_{ca} \mathcal{H}$. In particular,

T1. Is the transformation of Theorem 11(a) treewidth preserving?, i.e. for \mathcal{G} as defined, is $tw(\mathcal{G}) = tw(\mathcal{H})$?

We conjecture that this is, indeed, the case so that, even in the absence of a more searching analysis of the primal graph its treewidth would be at most $5tw(\mathcal{H}) + 4$. The assertion that T1 holds is, of course, trivially verified when $tw(\mathcal{H}) = 1$. By systematically considering the recursive constructions characterising the class, the same may be (rather tediously) inductively validated for those systems with $tw(\mathcal{H}) = 2$. A general argument covering $tw(\mathcal{H}) = k$ has, however, yet to be found.

A final group of problems regarding bounded treewidth systems concerns combining *dialogue game* methods, e.g. the TPI-disputes studied in [36,25], or the reasoning schema presented in [21], using both the graph-theoretic form of \mathcal{H} and a width k tree decomposition of \mathcal{H} . Among the reasons why treewidth decompositions may provide useful representations for both of these approaches are the following. The pathological examples for which exponential length TPI-disputes result constructed in [25], cannot occur in width k systems: the mechanism used to form

¹⁵ In addition, the methods of [29] require a further translation from CNF to a CSP problem in order to use an algorithm of Yannakakis [37].

such cases is via the translation of “provably hard” unsatisfiable CNF instances¹⁶: such instances, however, necessarily have primal graphs with large treewidth. Regarding the application to the dialogue structure promoted in [21], we observe that one standard design approach for efficient algorithms based on tree decompositions, discussed in [10], is to construct solutions working from the leaves of the tree decomposition building towards its root: such techniques mirror the reasoning methods discussed in [21].

9.3 Issues in Value-based Argumentation

The results presented in Section 8 indicate that efficient methods for the central decision questions – SBA and OBA – are unlikely to come about through simply limiting the underlying directed graph form: binary tree structures being the most basic non-trivial graph class.¹⁷ While Theorem 23 and Corollary 7 seem to offer rather pessimistic prospects for the possibility of developing tractable variants of SBA, these are in some respect unsurprising: a critical distinction between the nature of decision problems in VAFs and in standard argument systems concerns the search space examined.

For SBA this is the set of all specific audiences, i.e. the $k!$ total orderings of \mathcal{V} ; in decision problems such as CA, this space is the set of all subsets of \mathcal{X} , Searching over orderings of structures within combinatorial objects (as opposed to subsets) is known to give rise to decision questions which often remain hard even in restricted instances,¹⁸ a notable example being the *bandwidth minimisation* problem, [27, GT40, p. 200] that, like SBA is NP-hard even when restricted to binary trees.

It might, therefore, be argued that in order to identify non-trivial tractable variants of SBA, not only is it needed to restrict the underlying argument graph but also to restrict how the value set \mathcal{V} and mapping $\eta : \mathcal{X} \rightarrow \mathcal{V}$ interact with it. While, \mathcal{V} defines a parameter w.r.t which SBA is FPT – the procedure described in [7] giving

¹⁶ The notion of “hardness” is that of proof length within certain weak (but complete) propositional proof systems, see e.g. Cook and Reckhow [13], Beame and Pitassi [5], and Urquhart [35] for technical background. In [25] the TPI formalism is shown equivalent (in the sense of [13]) to the CUT-free Gentzen calculus.

¹⁷ One could limit structures further to, e.g. systems \mathcal{H} , with $D(\mathcal{H}) \leq 2$. In this case, retaining the connectivity assumption, one has only *paths* and simple cyclic structures: both cases are completely characterised in the original presentations of Bench-Capon [6,7].

¹⁸ The problem of deciding if an n -vertex graph has a hamiltonian cycle may appear to be an exception to this generalisation, however, one can sensibly treat the search space in this instance, not as all possible vertex orderings ($n!$), but rather as n element subsets of the edges: such viewpoints are exploited in efficient algorithms for testing hamiltonicity of graphs with small treewidth by progressively building “partial solutions” defining paths between vertex subsets.

a bound $O(k!|\mathcal{A}|)$ via the brute-force approach of testing each specific audience in turn – an open question is whether alternative approaches can succeed, i.e.

V1. Are there parameters other than $|\mathcal{V}|$ w.r.t. which SBA is FPT?

One aspect of the hardness proofs in Theorem 23 and those of [26,23], is that there is a single value (c) associated with “many” arguments, i.e. $|\eta^{-1}(c)| = \Theta(|\mathcal{X}|)$, and a large number of values (pos_i, neg_i) associated with only a few (at most 3 in the proof of Theorem 23) arguments. This suggests two possible approaches with which to consider alternative restrictions of SBA instances,

R1. by bounding the minimum and maximum number of occurrences of any given value $v \in \mathcal{V}$

R2. by bounding the number of occurrences of attacks $\langle x, y \rangle$ in which $\eta(x) = \eta(y)$.

The second of these is, again, motivated by recurring features in the hardness proofs, specifically the predominance of attacks involving two arguments with value c .

Theorem 24 and the trivial observation that at least one value must be common to $|\mathcal{X}|/|\mathcal{V}|$ arguments, however, limit the possible range of interest in trying to exploit R1: if $|\mathcal{V}| = o(|\mathcal{X}|)$, e.g. the case considered in Theorem 24, then some value is shared by $\omega(1)$ arguments. In trying to limit the number of occurrences of any value to be a constant – thus forcing $|\mathcal{V}| = \Theta(|\mathcal{X}|)$ – another difficulty arises. Thus, suppose $SBA^{(\mathcal{V}, \leq k)}$ is the decision problem SBA restricted to instances for which $\forall v \in \mathcal{V} |\eta^{-1}(v)| \leq k$, i.e. at most k arguments share a common value, $v \in \mathcal{V}$. Similarly, $SBA^{(T), (\mathcal{V}, \leq k)}$ is this problem with instances additionally restricted to trees.

Theorem 25 $SBA^{(T), (\mathcal{V}, \leq 3)}$ is NP-complete even if instances are binary trees.

Proof: The proof uses the binary tree structure of Corollary 7, with a modification of the definition of \mathcal{V} and the associated mapping η . Details are presented in Appendix 2. \square

The problem, $SBA^{(\mathcal{V}, \leq 1)}$ on the other hand is trivial: any argument, x , is subjectively accepted in such instances simply by choosing an audience in which $\eta(x)$ is the most preferred value. Between the extremes of this case and that of Theorem 25, we propose the following conjecture,

Conjecture 1 $SBA^{(\mathcal{V}, \leq 2)}$ is polynomial time decidable.

Regarding the approach suggested by R2, suppose we define the following param-

eter on VAFs:

$$\sigma(\langle \mathcal{H}(\mathcal{X}, \mathcal{A}), \mathcal{V}, \eta \rangle) = |\{\langle x, y \rangle \in \mathcal{A} : \eta(x) = \eta(y)\}|$$

(note that, retaining the assumptions of [6–8,26], cases $\eta(x) = \eta(y)$, $\langle x, y \rangle \in \mathcal{A}$ and $\langle y, x \rangle \in \mathcal{A}$ do not arise since there are no directed cycles all of whose arguments share the same value.)

Conjecture 2 *SBA is fixed parameter tractable w.r.t. to the parameter $\sigma(\langle \mathcal{H}, \mathcal{V}, \eta \rangle)$.*

These, again, are the subject of current work.

Appendix 1 – Further properties of \mathcal{G}_Φ

In this appendix we present the proof of the result stated in Theorem 8(b).

Proof: (of Theorem 8(b))

Recall that this asserts $\text{SA}^{(k)}$ and $\text{COHERENT}^{(k)}$ are Π_2^p -complete for k -partite systems with $k \geq 3$.

It suffices to construct a 3-partite argument system $\mathcal{G}_\Phi^{(3)}$ from the system \mathcal{G}_Φ of Section 3.2. Noting that Φ is sceptically accepted in the latter system if and only if $\Phi(Y_n, Z_n)$ is accepted as an instance of QSAT_2^Π , $\mathcal{G}_\Phi^{(3)}$ is designed to preserve this property. In order to form $\mathcal{G}_\Phi^{(3)}$ the subsystem of four arguments $\{\Phi, b_1, b_2, b_3\}$ in \mathcal{G}_Φ is replaced by the system of Fig. 10.

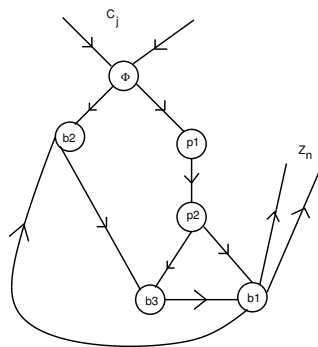

Fig. 10. Local Modification of the Argument system \mathcal{G}_Φ

From the properties of \mathcal{G}_Φ , it is still the case that for every satisfying instantiation of the CNF $\Phi(Y_n, Z_n)$ there is a preferred extension of $\mathcal{G}_\Phi^{(3)}$ containing Φ . Such preferred extensions additionally contain the argument p_2 . It follows easily from this that $\text{SA}(\mathcal{G}_\Phi^{(3)}, \Phi)$ holds if and only if $\Phi(Y_n, Z_n)$ is a positive instance of QSAT_2^Π . We

further observe that the system $\mathcal{G}_\Phi^{(3)}$ is coherent if and only if Φ is sceptically accepted. To complete the proof it remains to show that $\mathcal{G}_\Phi^{(3)}$ is 3-partite. We can construct a three colouring of $\mathcal{G}_\Phi^{(3)}$ by assigning colour R to $\{\Phi, y_1, \dots, y_n, z_1, \dots, z_n\}$; colour B to $\{\neg y_1, \dots, \neg y_n, \neg z_1, \dots, \neg z_n\}$ and G to $\{C_1, \dots, C_m\}$. This leaves the arguments $\{b_1, b_2, b_3, p_1, p_2\}$ uncoloured, however, the 3-colouring is completed using G for $\{p_1, b_1\}$; B for $\{b_2, p_2\}$; and R for $\{b_3\}$. \square

Appendix 2 – Proof of Theorem 25

Recall that Theorem 25 asserts $\text{SBA}^{(T), (\nu \leq 3)}$ is NP-complete even when instances are restricted to binary trees.

Given an instance, $\Phi(Z_n)$ of 3-SAT as in the proof of Theorem 23, i.e. in which every variable occurs in at most three distinct clauses¹⁹ of Φ , consider the instance of $\text{SBA}^{(T)} - \langle T_\Phi(\mathcal{X}, \mathcal{A}), \mathcal{V}_\Phi, \eta \rangle$ constructed. In this instance each of the values $v \in \{\text{pos}_i, \text{neg}_i : 1 \leq i \leq n\}$ has $|\eta^{-1}(v)| \leq 3$. Renaming the value c to v_1 , we have $|\eta^{-1}(v_1)| = m + 1$ – the argument Φ and the m arguments representing clauses. Introduce a new value v_2 together with arguments $a_{1,1}$ and $a_{1,2}$ and replace the sub-tree formed by $\{\Phi, C_1, C_2, \dots, C_m\}$ with the structure of Fig 11.

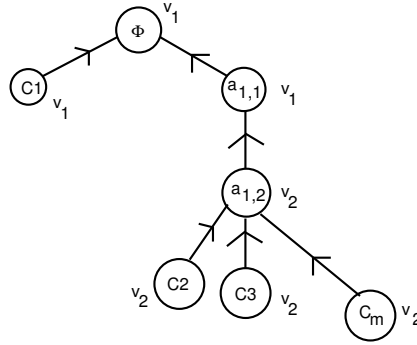

Fig. 11. Reducing number of occurrences of the value c in T_Φ

In the resulting tree there are now 3 occurrences of the value v_1 and m occurrences of the new value v_2 . Applying the same replacement method to the sub-tree with root $a_{1,2}$ and introducing a further new value v_3 , T_Φ will be modified to a tree, $T_\Phi^{(3)}$ with additional arguments

$$\{ a_{j,1}, a_{j,2} : 1 \leq j \leq m - 2 \}$$

¹⁹ In contrast to Theorem 23 in which this assumption is made for cosmetic purposes of presentational ease, in the current proof this variant of 3-SAT is needed in order to ensure appropriately few occurrences of the values pos_i and neg_i .

New attacks,

$$\begin{aligned} & \{ \langle a_{1,1}, \Phi \rangle, \langle C_m, a_{m-2,2} \rangle \} \cup \{ \langle a_{j,1}, a_{j-1,2} \rangle : 2 \leq j \leq m-2 \} \cup \\ & \{ \langle a_{j,2}, a_{j,1} \rangle : 1 \leq j \leq m-2 \} \cup \{ \langle C_j, a_{j-1,2} \rangle : 2 \leq j \leq m-1 \} \end{aligned}$$

and value set

$$\mathcal{V}^{(3)} = \mathcal{V}_\Phi \cup \{v_1, v_2, \dots, v_{m-1}\}$$

The mapping η as it effects clauses and these new arguments is now,

$$\eta(q) = \begin{cases} v_1 & \text{if } q \in \{\Phi, C_1, a_{1,1}\} \\ v_j & \text{if } q \in \{a_{j,1}, a_{j-1,2}, C_j\} \text{ and } 2 \leq j \leq m-2 \\ v_{m-1} & \text{if } q \in \{a_{m-2,2}, C_{m-1}, C_m\} \end{cases}$$

This now satisfies $|\eta^{-1}(v)| \leq 3$ for every value in $\mathcal{V}^{(3)}$.

The final stage is to replace the sub-trees rooted at each clause argument C_j using binary trees. The typical replacement is shown in Fig. 12

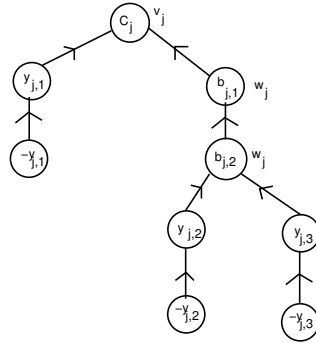

Fig. 12. Reducing clause sub-trees to binary trees in $T_\Phi^{(3)}$

In forming this final (binary) tree $2m$ new arguments are introduced, $\{b_{j,1}, b_{j,2} : 1 \leq j \leq m\}$ and a further m values $\{w_j : 1 \leq j \leq m\}$. The mapping η being extended for these new arguments via $\eta(b_{j,1}) = \eta(b_{j,2}) = w_j$.

We now claim that Φ is subjectively accepted in the resulting binary tree if and only if $\Phi(Z_n)$ is satisfiable.

Suppose first that $\Phi(Z_n)$ is satisfied using an instantiation $\underline{a} = \langle a_1, \dots, a_n \rangle$. Con-

sider any specific audience, α in which

$$\begin{aligned}
& pos_i \succ_\alpha neg_i \text{ if } a_i = \top \\
& neg_i \succ_\alpha pos_i \text{ if } a_i = \perp \\
& pos_i \succ_\alpha v_j \quad \forall 1 \leq i \leq n, 1 \leq j \leq m-1 \\
& neg_i \succ_\alpha v_j \quad \forall 1 \leq i \leq n, 1 \leq j \leq m-1 \\
& pos_i \succ_\alpha w_j \quad \forall 1 \leq i \leq n, 1 \leq j \leq m \\
& neg_i \succ_\alpha w_j \quad \forall 1 \leq i \leq n, 1 \leq j \leq m \\
& w_j \succ_\alpha v_j \quad \forall 1 \leq j \leq m-1 \text{ and } w_m \succ_\alpha v_{m-1} \\
& v_j \succ_\alpha v_{j-1} \quad \forall 2 \leq j \leq m-1
\end{aligned}$$

Since \underline{a} satisfies $\Phi(Z_n)$ each clause C_j has at least one literal, assigned the value \top : if the corresponding literal in $T_\Phi^{(3)}$ is the (unique) literal attacking the clause C_j then this attack is successful; otherwise the corresponding literal (successfully) attacks $b_{j,2}$ so that $b_{j,1}$ successfully attacks C_j . It follows that in the unique preferred extension, $P(\alpha)$ induced by $P(\alpha) \cap \{C_1, \dots, C_m\} = \emptyset$. From this, and the ordering $v_j \succ_\alpha v_{j-1}$ we deduce that the attack by $a_{j,2}$ on $a_{j,1}$ succeeds for each $1 \leq j \leq m-2$, i.e. $\{a_{1,2}, \dots, a_{m-2,2}\} \subset P(\alpha)$ and hence $\Phi \in P(\alpha)$ as claimed.

One the other hand suppose the audience α is such that $\Phi \in P(\alpha)$. From the same reasoning as that in the proof of Theorem 23 we can construct an instantiation, $\underline{a} = \langle a_1, \dots, a_n \rangle$ of Z_n via $a_i = \top$ if and only if $pos_i \succ_\alpha neg_i$. Now since $\Phi \in P(\alpha)$ an easy argument establishes $a_{j,1} \notin P(\alpha)$ and $a_{j,2} \in P(\alpha)$ for every $1 \leq j \leq m-2$. To complete the proof it suffices to show that this instantiation must satisfy $\Phi(Z_n)$. Suppose, to the contrary, that $\Phi(\underline{a}) = \perp$ and let C_j be any clause that it is falsified by \underline{a} . Consider the corresponding argument, C_j within $T_\Phi^{(3)}$. It cannot be the case that $C_j = C_1$: for in that case the attack by C_1 on Φ succeeds, contradicting the assumption that $\Phi \in P(\alpha)$. The alternative, however, is that C_j attacks some argument $a_{j-1,2}$ or $a_{m-2,2}$ for $C_j = C_m$. Again C_j falsified by \underline{a} contradicts the property $a_{j,2} \in P(\alpha)$ which holds of any preferred extension with respect to α containing Φ . Thus, every clause of $\Phi(Z_n)$ must be satisfied by \underline{a} and it follows that from a specific audience under which Φ is subjectively accepted we can construct a satisfying instantiation of $\Phi(Z_n)$.

References

- [1] L. Amgoud and C. Cayrol. A reasoning model based on the production of acceptable arguments. *Annals of Math. and Artificial Intelligence*, 34:197–215, 2002.

- [2] S. Arnborg, J. Lagergren, and D. Seese. Easy problems for tree-decomposable graphs. *Jnl. of Algorithms*, 12:308–340, 1991.
- [3] P. Baroni and M. Giacomin. Solving semantic problems with odd-length cycles in argumentation. In *Proc. 7th European Conf. on Symbolic and Quantitative Approaches to Reasoning With Uncertainty (ECSQARU)*, volume 2711 of *LNAI*, pages 440–451. Springer-Verlag, 2003.
- [4] P. Baroni, M. Giacomin, and G. Guida. SCC-recursiveness: a general schema for argumentation semantics. *Artificial Intelligence*, 168(1–2):162–210, 2005.
- [5] P. Beame and T. Pitassi. Propositional proof complexity: Past, present, and future. *Bulletin of the EATCS*, 65:66–89, 1998.
- [6] T. J. M. Bench-Capon. Agreeing to Differ: Modelling Persuasive Dialogue Between Parties With Different Values. *Informal Logic*, 22(3):231–245, 2002.
- [7] T. J. M. Bench-Capon. Persuasion in Practical Argument Using Value-based Argumentation Frameworks. *Journal of Logic and Computation*, 13(3):429–448, 2003.
- [8] T. J. M. Bench-Capon, S. Doutre, and P. E. Dunne. Audiences in argumentation frameworks. *Artificial Intelligence*, 2006. (to appear).
- [9] C. Berge. *Graphs and Hypergraphs*. North-Holland, Amsterdam, 1973.
- [10] H. L. Bodlaender. Dynamic programming on graphs with bounded treewidth. In *Proc. 15th ICALP*, volume 317 of *LNCS*, pages 105–119, Berlin, 1988. Springer-Verlag.
- [11] H. L. Bodlaender. A partial k -arboretum of graphs with bounded treewidth. *Theoretical Computer Science*, 209:1–45, 1998.
- [12] A. Bondarenko, P.M. Dung, R.A. Kowalski, and F. Toni. An abstract, argumentation-theoretic approach to default reasoning. *Artificial Intelligence*, 93:63–101, 1997.
- [13] S. A. Cook and R. A. Reckhow. The relative complexity of propositional proof systems. *Journal of Symbolic Logic*, 44(1):36–50, 1979.
- [14] S. Coste-Marquis, C. Devred, and P. Marquis. Symmetric argumentation frameworks. In L. Godo, editor, *Proc. 8th European Conf. on Symbolic and Quantitative Approaches to Reasoning With Uncertainty (ECSQARU)*, volume 3571 of *LNAI*, pages 317–328. Springer-Verlag, 2005.
- [15] B. Courcelle. The monadic second-order logic of graphs. I. recognizable sets of finite graphs. *Information and Computation*, 85(1):12–75, 1990.
- [16] B. Courcelle. The monadic second-order logic of graphs III: tree-decompositions, minor and complexity issues. *Informatique Théorique et Applications*, 26:257–286, 1992.
- [17] Y. Dimopoulos, B. Nebel, and F. Toni. On the computational complexity of assumption-based argumentation for default reasoning. *Artificial Intelligence*, 141:55–78, 2002.

- [18] Y. Dimopoulos and A. Torres. Graph theoretical structures in logic programs and default theories. *Theoretical Computer Science*, 170:209–244, 1996.
- [19] R. G. Downey and M. R. Fellows. Fixed parameter tractability and completeness I: basic results. *SIAM Jnl. on Computing*, 24:873–921, 1995.
- [20] P. M. Dung. On the acceptability of arguments and its fundamental role in nonmonotonic reasoning, logic programming and n -person games. *Artificial Intelligence*, 77:321–357, 1995.
- [21] P. M. Dung, R. A. Kowalski, and F. Toni. Dialectic proof procedures for assumption-based, admissible argumentation. *Artificial Intelligence*, 170(2):114–159, 2006.
- [22] P. E. Dunne. *The complexity of Boolean networks*. Academic Press, 1988.
- [23] P. E. Dunne. Complexity properties of restricted abstract argument systems. In P. E. Dunne and T. J. M. Bench-Capon, editors, *Computational Models of Argument (Proc. COMMA 2006)*, volume 144 of *Frontiers in Artificial Intelligence and Applications*, pages 85–96, Amsterdam, 2006. IOS Press.
- [24] P. E. Dunne and T. J. M. Bench-Capon. Coherence in finite argument systems. *Artificial Intelligence*, 141:187–203, 2002.
- [25] P. E. Dunne and T. J. M. Bench-Capon. Two party immediate response disputes: properties and efficiency. *Artificial Intelligence*, 149:221–250, 2003.
- [26] P. E. Dunne and T. J. M. Bench-Capon. Complexity in value-based argument systems. In *Proc. 9th JELIA*, volume 3229 of *LNAI*, pages 360–371. Springer-Verlag, 2004.
- [27] M. R. Garey and D. S. Johnson. *Computers and Intractability: A Guide to the Theory of NP-Completeness*. W. H. Freeman: New York, 1979.
- [28] L. A. Goldberg. *Efficient algorithms for listing combinatorial structures*. Cambridge Univ. Press, 1993.
- [29] G. Gottlob, F. Scarcello, and M. Sideri. Fixed-parameter complexity in AI and nonmonotonic reasoning. *Artificial Intelligence*, 138:55–86, 2002.
- [30] J. E. Hopcroft and J. K. Wong. Linear time algorithm for isomorphism of planar graphs (preliminary report). In *STOC '74: Proc. of the 6th Annual ACM symposium on Theory of computing*, pages 172–184, New York, NY, USA, 1974. ACM Press.
- [31] R..J. Lipton and R. E. Tarjan. A separator theorem for planar graphs. *SIAM Jnl. Applied Math.*, 36:177–189, 1979.
- [32] W. F. McColl. Planar crossovers. *IEEE Trans. Computers*, C-30:223–225, 1981.
- [33] C. H. Papadimitriou. *Computational Complexity*. Addison-Wesley, 1994.
- [34] N. Robertson and P. D. Seymour. Graph minors II: algorithmic aspects of treewidth. *Jnl. of Algorithms*, 7:309–322, 1986.
- [35] A. Urquhart. The complexity of propositional proofs. *Bulletin of Symbolic Logic*, 1(4):425–467, 1995.

- [36] G. Vreeswijk and H. Prakken. Credulous and sceptical argument games for preferred semantics. In *Proceedings of JELIA'2000, The 7th European Workshop on Logic for Artificial Intelligence.*, pages 224–238, Berlin, 2000. Springer LNAI 1919, Springer Verlag.
- [37] M. Yannakakis. Algorithms for acyclic database schemes. In C. Zaniolo and C. Delobel, editors, *Proc. Internat. Conference on Very Large Data Bases (VLDB'81)*, pages 82–94, 1981.